

1TRIPR II ROW UNITS Operator's Manual

Part #125-082-01-EN-OM

Rev. A



Intentionally Left Blank Page

Table of Contents

Introduction

To the Dealer	1-2
Delivery	1-2
Product Description	1-3
Purpose of This Manual	1-3
Warranty	1-4

Safety Information

Farm Safety	2-2
How You Can Improve Farm Safety	2-2
High Risk Factors on Farms	2-2
The Benefits of Improved Safety and Health Practices	2-2
Health and Safety Hazards on Farms	2-3
Safety Alert Symbol	2-4
Be Aware of Signal Words	2-4
Shutdown and Storage	2-4
For Your Protection	2-4
Equipment Safety Guidelines	2-5
Safe Transport	2-5
Safe Operation	2-5
Warning and Safety Lights	2-6
Rear View of Toolbar	2-6
Slow Moving Vehicle (SMV)	2-7
No Riders	2-7
Prepare for Emergencies	2-7
Safety Never Hurts	2-7
Practice Safe Maintenance	2-8
Anhydrous Ammonia (NH ₃) and Liquid Fertilizer	2-9
Orthman Serial Number Plate	2-9
Safety Decals	2-10
Orthman Right Side Decals	2-10
Orthman Left Side Decals	2-11

Major Components

Main Frame	3-2
Tail Section	3-3
Rolling Basket Assembly	3-4
Coastal Plains Roller Assembly	3-5

Preparation and Setup

Shipping Configuration	4-2
Preparing the 1tRIPr® II Row Unit	4-3
Implement-to-Tractor Connection	4-3
Tooling Options	4-4
Individual Row Units	4-4
Mounting Row Unit	4-4
Row Unit Set-Back Clamp	4-6
Mounting Set-Back Clamp	4-6
Rolling Basket Assembly	4-8
Rolling Basket Assembly Installation	4-8
Tillage Shank	4-9
Shallow Tillage Assembly	4-9
Liquid Fertilizer Mole Shank Assembly	4-9
Mole Knife Assembly	4-10
AA Knife Assembly	4-10
Dry Mole Shank Assembly	4-11
Air Diffuser Installation	4-11
Tillage Shank Installation	4-12
Mole Shank Assembly Fertilizer Tube Installation	4-13
Mole Knife Assembly Fertilizer Tube Installation	4-14
Dry Mole Shank Assembly Fertilizer Tube and Dry Boot Installation	4-15
Mole Shank Shin Cap Installation	4-16
Automatic Reset (AR) Trip Linkage Installation	4-17

Operation and Field Settings

Toolbar Height and Orientation	5-2
Row Unit Depth	5-2
Field Adjustments	5-4
Row Unit Down Pressure	5-4
Row Unit Down Pressure Adjustment	5-5
Row Cleaner Assembly Depth	5-6
Row Cleaner Assembly Width	5-8
Fore and Aft Adjustment	5-8
Rigid Row Cleaner	5-9
Floating Row Cleaner	5-10
Rolling Basket Down Pressure	5-11
Rolling Basket Down Pressure Adjustment	5-11
Tillage Shank Assembly Depth	5-12
Tillage Shank Assembly Depth Adjustment	5-12
Tillage Shank Depth Adjustment Chart	5-12
Wavy Coulter Assembly Depth and Width	5-14
Wavy Coulter Assembly Depth Adjustment	5-14
Wavy Coulter Assembly Width Adjustment	5-15
Wavy Coulter Assembly Fore and Aft	5-16
Adjustable Liquid Tubes	5-18
Adjustable Dry Fertilizer Boot on Dry Mole Shank	5-19
Shear Bolt Protected Tail	5-20
Automatic Reset (AR) Trip Linkage	5-21

Troubleshooting

Row Unit Tooling Does Not Penetrate Soil. Wing Row Units Float Upward.	6-2
Row Unit Plugs With Field Residue Between the Depth Band Coulter Assembly and Row Cleaner Assembly	6-2
Row Unit Plugs With Field Residue Between the Row Cleaner Assembly and Tillage Shank.	6-2
Row Unit Plugs With Field Residue Between the Tillage Shank and Wavy Coulters.	6-2
Field Residue Plugs Between Row Units.	6-3
Row Unit Does Not Trip or Trips Too Easily.	6-3
Shear Bolt Will Not Shear or Shears Too Easily.	6-3

Maintenance and Specifications

Practice Safe Maintenance	7-2
Torque Specifications	7-2
Standard Fasteners	7-2
Metric Fasteners	7-3
Lubrication	7-4
Implement Inspection	7-4
Implement Storage	7-4
Specifications	7-5
Notes	7-8

Page Intentionally Blank

Chapter 1

Introduction

To the Dealer	1-2
Delivery	1-2
Product Description	1-3
Purpose of This Manual	1-3
Warranty	1-4

To the Dealer

This instruction contains important information for unloading of the 1tRIPr® II Row Unit. Read instructions carefully before attempting to unload. While the 1tRIPr® II is considered a factory assembled product, some components may have been removed from the machine to prevent damage during shipping, or to allow for consolidated shipments. Make sure all components are properly installed.

Inspect the implement thoroughly after assembly to be certain it is functioning properly before delivering it to the customer. The following checklist is a reminder of points to cover. Check off each item as it is found satisfactory or after proper adjustment is made.

Pre-Delivery Checklist	
	All hardware is properly tightened.
	Lubrication of grease fittings has been completed.
	All decals are properly located and readable.
	All implement tools and options are installed and set.
	Check overall condition of implement.
	Make sure operator's manual is included.
Date set up:	
Signature:	

Delivery

At the time the machine is delivered, the following checklist is a reminder of information which should be conveyed directly to the customer. Check off each item as it is fully explained to customer.

Delivery Checklist	
	Introduce the machine to the customer. Give the customer the operator's manual and encourage them to read it.
	Make the customer aware of all the safety precautions that must be exercised when using and transporting the machine.
	Make customer aware of the different tooling options available.
	The machine does not come set to run in the field from the factory. See Chapter 5, "Operation and Field Settings" to help set the machine for optimal performance. Explain all operating adjustments.
	Explain to the customer that the life expectancy of this machine depends on regular maintenance as directed in the operator's manual.
	Tell the customer to use the proper tools for service and inform them of Orthman parts availability.
	Review recommended procedures for attaching and detaching implement from tractor.
	Inform the customer of safety precautions that must be observed when transporting.
	When the machine is transported on a road or highway at night or during the day, accessory lights and devices should be used for adequate warning to operators of other vehicles. In this regard, tell customer to check local governmental regulations.
	Write machine model number and serial number in the spaces provided below.
	To the best of my knowledge, this machine has been delivered ready for field use and the customer has been fully informed as to proper operation and care.
Date delivered:	Model number:
Signature:	Serial number:

NOTE: After signing, copy this page. Keep signed delivery checklist in machine file at the dealership.

Product Description

The Orthman 1tRIPr® II Row Unit preplant tillage tool combines the following three principals of successful precision strip tillage:

1. Ideal Seedbed Preparation
 - For a quick start and robust germination, the 1tRIPr® II maximizes existing soil moisture and increases water infiltration to create a warm, consistent seedbed with uniform seed-to-soil contact.
2. Precision Nutrient Placement
 - The 1tRIPr® II works with dry, liquid, or NH₃ fertilizers and its independent row-depth control allows a precise placement of multiple nutrients at variable depths for uptake timing.
3. Optimal Root Zone Conditioning
 - The 1tRIPr® II creates an ideal environment throughout the growing cycle by shattering compaction in the root-zone, eliminating subsoil voids and cavities, and creating twice as many beneficial pores for improved below-ground development.

Orthman's parallel linkage provides a robust foundation and allows the row unit to operate independently of the toolbar for consistent depth control and fertilizer placement in uneven field conditions.

The rugged depth band coulter cuts through surface and sub-surface residue to eliminate interference with the shank while it simultaneously maintains a precise control of seedbed depth.

The auto-reset linkage allows the row unit to be tripped up and over underground obstructions, and then automatically resets.

An adjustable row cleaner features rugged, notched disc blades to remove plant residue from the strip, clearing a path for rear tooling and the subsequent planter operation.

Orthman's precision tillage shank shatters compaction, eliminates subsoil voids, increases water infiltration, and promotes vigorous root growth through all stages of seed development.

The depth-controlled, width-adjustable wavy coulters provide "lift and pinch" tillage to capture loosened soil and create a firm consistent strip.

The 1tRIPr® II rolling basket features adjustable down pressure to help break up remaining clods and ensure smooth planter operation.

Purpose of This Manual

This manual is considered to be an integral component of the 1tRIPr® II Row Units and is designed to educate the owner and operators regarding safety, operation, maintenance, troubleshooting, and component identification.

All personnel involved in the operation of the 1tRIPr® II Row Units are responsible for reading and understanding the entire contents of this manual. This manual is designed to keep the operator safe and knowledgeable, as well as prolong the life of the product, minimize downtime, and maximize field efficiency. This manual should accompany the product if it is ever sold.

We would like to thank you for placing your confidence in Orthman Mfg., Inc. Your 1tRIPr® II Row Units are manufactured to meet the highest standards and is built with Orthman precision and strength to increase your agricultural operation's dependability and profitability.

Warranty

Orthman Manufacturing, Inc. ("OMI") warrants each new whole good product to be free from defects in manufactured components and workmanship. This warranty is applicable only for the normal service life expectancy of the product or components, not to exceed twenty-four (24) consecutive months from date of purchase of the new OMI product to the original purchaser.

Purchased components installed by OMI (blades, bearings, controls, hoses, wheels, coulters, cylinders, fittings, points, etc.) shall be warranted by their respective manufacturer for a period of twelve (12) consecutive months from date of purchase of the new OMI product to the original purchaser.

A completed online Warranty Registration for the original purchaser must have been received by OMI to activate warranty coverage. Non receipt of warranty registration may void OMI warranty coverage. OMI warranty is non-transferable.

Genuine OMI replacement parts and components will be warranted for ninety (90) days from date of purchase or the remainder of the original equipment warranty period; whichever is greater.

All warranty work is to be performed by an authorized OMI dealer at the repairing dealer's location unless otherwise approved by Orthman Manufacturing, Inc. – Lexington, Nebraska.

Under no circumstances shall warranty cover any merchandise or component thereof, which, in the opinion of OMI, has been subjected to misuse, unauthorized modifications or alteration, accident, collision with obstruction/ground, or if repairs have been made with parts other than those approved by OMI. If the seal on the cylinder is broke (cylinder opened), it will void all warranty for cylinder.

OMI warranty policies do not cover travel expenses, after hours field/service time, overnight expenses, or expenses not related to that of regular shop labor rates or parts replaced during actual warranty repair. OMI reserves the right to adjust warranty labor credits so as not to exceed believed normal repair times as directed by warranty governing laws.

OMI obligation under this warranty shall be limited to repairing or replacing, free of charge to the purchaser, any part, in our judgment, showing evidence of such defect, provided further that such part shall be returned within thirty (30) days from the date of repair to OMI through the dealer or distributor from whom the product was purchased or repaired; transportation charges prepaid.

This warranty shall not be interpreted to render OMI liable for injury or damages of any kind or nature to person or property. This warranty does not extend to the loss of crops, loss of delay in harvesting/planting, or any expense or loss incurred for labor, substitute machinery, rental, or any subsequent reasons thereof.

Except as set forth above, OMI shall have no obligation or liability of any kind on account of its equipment and shall not be liable for special or consequential damages. OMI makes no other warranty, expressed or implied, and, specifically, OMI disclaims any implied warranty or merchantability or fitness for a particular purpose. Some sates or provinces do not permit limitations or exclusions of implied warranties or incidental or consequential damages, so the limitations or exclusion in this warranty may not apply.

This warranty is subject to any existing conditions of supply, which may directly affect OMI ability to obtain materials or manufacture replacement parts.

OMI reserves the right to make improvements in design or changes in specifications at any time, without incurring any obligation to owners of units previously sold.

No one person is authorized to alter, modify or enlarge this warranty nor the exclusions, limitations and reservations. For more information, please visit OMI website www.orthman.com.

Information subject to change without notice.

Provided warranty policy information supersedes all previous warranty considerations.

Orthman Manufacturing, Inc. – Lexington, NE

Rev. Date - 8/1/2021

Chapter 2

Safety Information

Farm Safety	2-2
How You Can Improve Farm Safety	2-2
High Risk Factors on Farms	2-2
The Benefits of Improved Safety and Health Practices	2-2
Health and Safety Hazards on Farms	2-3
Safety Alert Symbol	2-4
Be Aware of Signal Words	2-4
Shutdown and Storage	2-4
For Your Protection	2-4
Equipment Safety Guidelines	2-5
Safe Transport	2-5
Safe Operation	2-5
Warning and Safety Lights	2-6
Rear View of Toolbar	2-6
Slow Moving Vehicle (SMV)	2-7
No Riders	2-7
Prepare for Emergencies	2-7
Safety Never Hurts	2-7
Practice Safe Maintenance	2-8
Anhydrous Ammonia (NH ₃) and Liquid Fertilizer	2-9
Orthman Serial Number Plate	2-9
Safety Decals	2-10
Orthman Right Side Decals	2-10
Orthman Left Side Decals	2-11

Farm Safety

Contrary to the popular image of fresh air and peaceful surroundings, a farm is not a hazard-free work setting. Every year, thousands of farm workers are injured and hundreds more die in farming accidents. According to the National Safety Council, agriculture is the most hazardous industry in the nation.

How You Can Improve Farm Safety

You can start by increasing your awareness of farming hazards and making a conscious effort to prepare for emergency situations including fires, vehicle accidents, electrical shocks from equipment and wires, and chemical exposures. Be especially alert to hazards that may affect children and the elderly. Minimize hazards by carefully selecting the products you buy to ensure that you provide good tools and equipment. Always use seat belts when operating tractors, and establish and maintain good housekeeping practices. Here are some other steps you can take to reduce illnesses and injuries on the farm:

- Read and follow instructions in equipment operator's manuals and on product labels.
- Inspect equipment routinely for problems that may cause accidents.
- Discuss safety hazards and emergency procedures with your workers.
- Install approved rollover protective structures, protective enclosures, or protective frames on tractors.
- Make sure that guards on farm equipment are replaced after maintenance.
- Review and follow instructions in material safety data sheets (MSDSs) and on labels that come with chemical products and communicate information on these hazards to your workers.

High Risk Factors on Farms

The following factors may increase risk of injury or illness for farm workers:

- Age — Injury rates are highest among children age 15 and under and adults over 65.
- Equipment and Machinery — Most farm accidents and fatalities involve machinery. Proper machine guarding and performing equipment maintenance according to manufacturers' recommendations can help prevent accidents.
- Protective Equipment — Using protective equipment such as seat belts on tractors and personal protective equipment (PPE) (safety gloves, coveralls, boots, hats, aprons, goggles, and face shields) could significantly reduce farming injuries.
- Take precautions to prevent entrapment and suffocation caused by unstable surfaces of grain storage bins, silos, or hoppers. Never "walk the grain."
- Be aware that methane gas, carbon dioxide, ammonia, and hydrogen sulfide can form in unventilated grain silos and manure pits and can suffocate or poison workers or explode.
- Take advantage of safety equipment, such as bypass starter covers, power take-off master shields, and slow-moving vehicle emblems.
- Medical Care — Hospitals and emergency medical care are typically not readily accessible in rural areas near farms.

The Benefits of Improved Safety and Health Practices

Orthman Manufacturing provides this document in the hope that everyone that has a job to do, does it SAFELY. Our goal and yours should be to end each day in the best possible health. Better safety and health practices reduce fatalities, injuries, and illnesses as well as associated costs such as workers' compensation insurance premiums, lost production, and medical expenses. A safer and more healthful workplace improves morale and productivity.

Health and Safety Hazards on Farms

Farm workers including farm families and migrant workers are exposed to hazards such as the following:

Danger	Potential Effect or Injury	Prevention
Chemicals/ Pesticides	Skin and respiratory injury or death	Review material safety data sheets (MSDSs) and manufacturers' data sheets, and use proper personal protective equipment (PPE).
Cold	Illness, frostbite, or death	Dress properly for the day.
Dust	Respiratory injury or explosive combinations	Be aware of your surroundings and activity.
Electricity	Shock, burns, fire, or death	Use a qualified professional for wiring dangerous electrical devices. Never overload a circuit. Replace damaged electrical devices or cords. Electrical tape will not insulate you from injury.
Grain bins/Silos	Entrapment or suffocation Explosion from formation of dangerous gases and poisoning	Make sure the bin is properly ventilated and maintained. Never "walk the grain."
Hand tools	Injury including cuts, abrasions, electrocution, strains, sprains, or death	Make sure hand tools are in good condition. Never leave a damaged tool accessible for someone else to use.
Highway traffic	Collisions resulting in injury or death	Follow regulations and stay alert. Avoid alcohol use and the use of communication devices while driving.
Lifting/ Lifting devices	Back injury, sprains, or strains Falling material resulting in being struck or crushed by heavy material	Use proper lifting technique. Get help when the load is too heavy. Inspect all lifting chains, straps, or cables routinely to make sure they are in good condition.
Livestock handling	Serious injury or death resulting from being pinned, struck, or trampled	Always make sure you have adequate room and an escape route.
Machinery/ Equipment	Cuts, abrasions, amputations, or death	Thoroughly read and understand your Owners Equipment Manual (OEM). Never operate the equipment without guards in place. Make sure the equipment can not be energized or otherwise put into operation during repair or maintenance.
Manure pits	Suffocation or poisoning Explosion from formation of dangerous gases and poisoning	Keep proper maintenance.
Mud	Sprains, strains, entrapment, or suffocation. Eye injury and skin irritation.	Use proper PPE. In some conditions a "spotter" may be needed.
Noise	Hearing damage	Use proper PPE.
Ponds	Drowning	Put on a life preserver and make sure help is readily available.
Slips/Trips/Falls	Sprains, strains, back and neck injury, bone breaks, or death	Keep work area free from clutter and organized. If working on anything elevated, make sure you have appropriate guarding and/or fall protection such as a harness and lanyard.
Sun/Heat	Sun burn, heat stroke, shock, or death	Use common sense on excessively hot days. Use sun screen, put on a hat, and stay hydrated.
Toxic gases	Skin and respiratory injury or death Explosion	Review MSDSs and manufacturers' data sheets, and use proper PPE.
Tractors	Cuts, abrasions, amputations, or death	Thoroughly read and understand your OEM. Never operate the equipment without guards in place or anti-roll over devices.
Wells	Electrocution, amputation, or death	Avoid contact with water while working on an electrical device. Make sure the equipment can not be energized or otherwise put into operation during repair or maintenance. Make sure all guarding is in place.
Severe weather	Electrocution, "struck by" injuries, or death	Move to a safe place. Lightening, hail, and tornadoes are unpredictable.

Orthman Manufacturing, Inc. does not limit the potential effects or injuries nor prevention measures to those listed above. They are provided solely as a guideline to making your farm life safer. Always consult your Owner/Operators Manual for specific tool and equipment safety requirements.

Safety Alert Symbol



This safety alert symbol warns of potential hazards to personal safety and that extra precautions must be taken.

When you see this symbol, carefully read the message(s) that follow. Follow all recommended precautions and safe operating practices in this manual.

Hazard control and accident prevention are dependent upon the safety awareness and proper training of personnel involved in the operation of this implement.

Be Aware of Signal Words

Signal words designate a degree or level of hazard seriousness. These signal words include:

DANGER

DANGER indicates a hazardous situation that, if not avoided, will result in death or serious injury. **DANGER** is limited to extreme situations, typically for machine components which for functional purposes cannot be guarded.

WARNING

WARNING indicates a potentially hazardous situation that, if not avoided, could result in death or serious injury. **WARNING** includes hazards that are exposed when safety guards are removed. **WARNING** may also be used to alert against unsafe practices.

CAUTION

CAUTION indicates a potentially hazardous situation that, if not avoided, may result in minor or moderate injury. **CAUTION** may also be used to alert against unsafe practices.

Shutdown and Storage

DANGER

Avoid crushing. Failure to follow this information will result in death or serious injury. Make sure all personnel are clear of the implement before lowering.

Lower the implement to the ground, place the tractor in park, turn off the engine, and remove the key.

DANGER

Avoid crushing. Failure to follow this information will result in death or serious injury. Use bar stands and cylinder stops to support the implement.

Store the implement on a clean, dry, and level surface. An uneven surface could cause the implement to shift or fall, resulting in injury or death as well as implement damage. Securely support all implement components that must be raised. Store the implement away from human activity.

For Your Protection

CAUTION

Read and understand the entire contents of this manual before operating or servicing the implement.

Read and understand all operator manuals for the machinery used in conjunction with Orthman equipment.

Carefully read all safety decals in this manual as well as on the implement. Keep the implement clean so decals are easily visible. Keep all safety decals in good, clean, and legible condition. Immediately replace damaged and/or missing decals. Replacement decals are available from your Orthman dealer.

Learn to operate the implement and all components properly. Do not let others operate the implement without proper instruction. Unauthorized implement modifications may impair function and safety. If you do not understand any content in this manual or need assistance, contact your Orthman dealer.

Equipment Safety Guidelines

Operator safety is the primary concern when designing an Orthman implement. Orthman integrates as many safety features into the implement as possible. You can avoid many hazards and possible accidents by observing precautions in this safety section.

Insist that yourself and personnel working with and around you follow all safety precautions. Be cautious when working with or around the implement to avoid injury.

Safe Transport

Use the following guidelines for safe transport:

- Engage transport locking devices and cylinder stops prior to transport.
- Plan your route to avoid traffic. Yield to traffic in all situations.
- Various conditions will require reduced speed. Travel at speeds that allow for adequate control of stopping and steering.

DANGER

Avoid electrocution. Failure to follow this information will result in death or serious injury. Be aware of overhead power lines.

- Use extreme care when operating the implement near power lines. Contact or close proximity to power lines can result in injury or death.
- Know the transport height and gross weight of the implement. Avoid overhead obstructions not allowing your transport height. Do not use bridges rated below the gross weight of the implement.
- Make sure a slow moving vehicle (SMV) placard is mounted to the implement and is easily visible to other motorists. See “Slow Moving Vehicle (SMV)” on page 2-7.
- Make allowances for implement size when transporting. Sudden braking can cause a towed load to swerve and/or rollover. Never use independent braking with the implement in tow as loss of control and/or rollover can result. Reduce speed if the towed implement is not equipped with brakes.
- Do not coast. Always keep the tractor or towing device in gear to provide engine braking when traveling downhill.
- Comply with state and local laws governing implement transport.

Safe Operation

CAUTION

Read and understand the entire contents of this manual before operating or servicing the implement.

The implement is to be operated by qualified personnel only. Never let children operate the implement. A complete understanding of safety precautions, operation, and maintenance is mandatory before implement use.

DANGER

Avoid electrocution. Failure to follow this information will result in death or serious injury. Be aware of overhead power lines.

Use extreme care when operating the implement near power lines. Contact or close proximity to power lines can result in injury or death.

Know the transport height and gross weight of the implement. Avoid overhead obstructions not allowing your transport height. Do not use bridges rated below your gross weight.

DANGER

Avoid rollover. Failure to follow this information will result in death or serious injury. Do not fold or unfold the implement when on a hillside and avoid sharp turns, as shift of weight could cause rollover.

Operate the implement at a safe distance from terrain irregularities and other obstructions that could cause rollover.

WARNING

Avoid being struck by the implement. Failure to follow this information could result in death or serious injury. Make sure all personnel are clear of the implement at all times when the implement is in motion.

Be aware of obstructions above, below, and around the implement when in operation or transport.

Warning and Safety Lights

Oversized implements and slow moving vehicles create a hazard when transported on public roads. Use safety lighting when traveling on public roads day and night.

Make sure all warning lights, safety lights, and turning signals are working and clean. Replace missing or damaged lights immediately. Comply with state and local laws governing implement safety lighting.

Rear View of Toolbar

See Figure 2-1.

NOTES:

- Two-sided amber lights (3) must be visible from the front and rear of the implement.
- Orthman double bar toolbar is shown. Orthman rigid toolbar is similar.

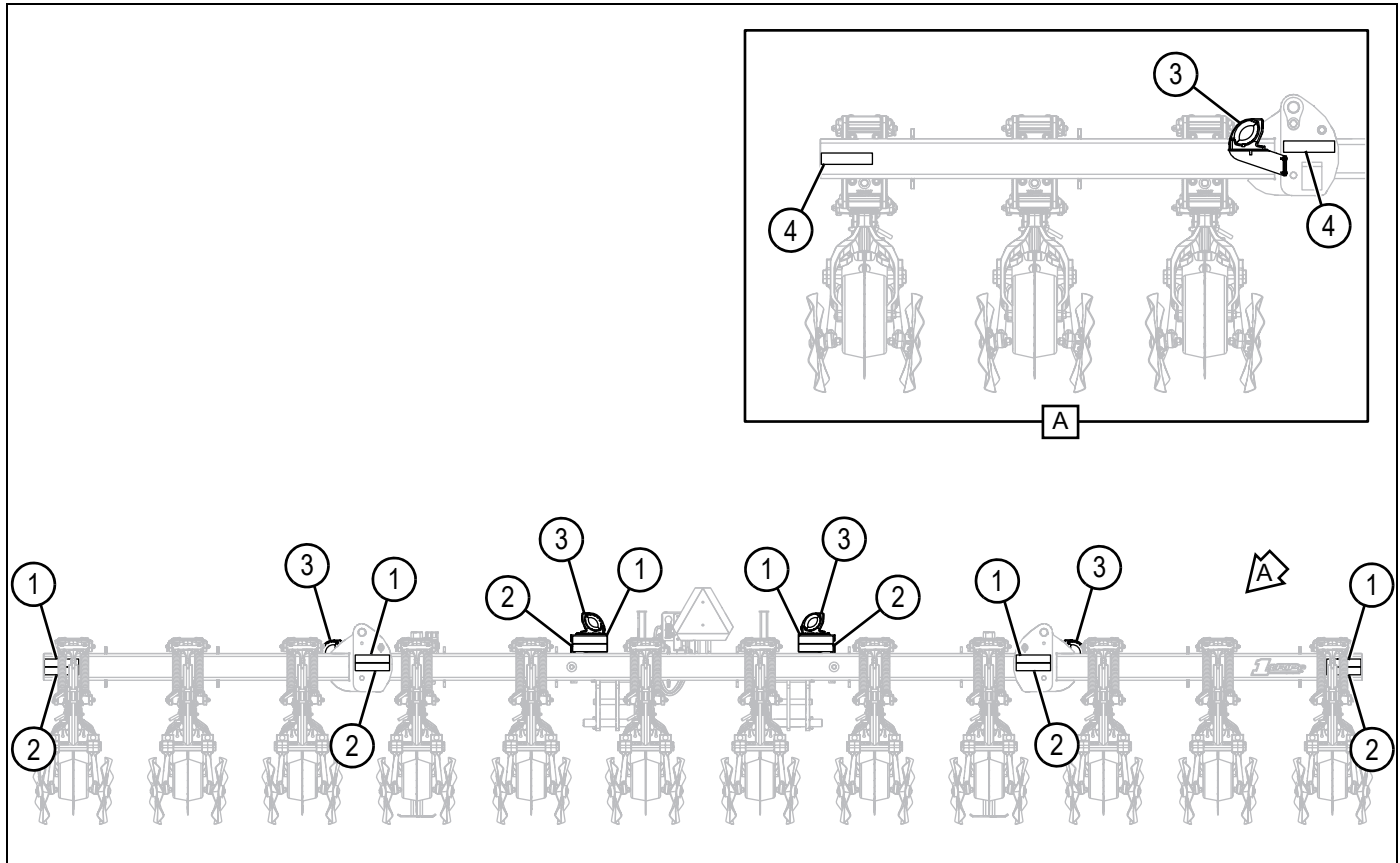

Figure 2-1

ORM000298

- 1) Orange fluorescent non-reflective decal (6 used)
- 2) Red retroreflective decal (6 used)

- 3) Two-sided amber light (4 used)
- 4) Yellow reflective decal (4 used)

Slow Moving Vehicle (SMV)

The slow moving vehicle (SMV) placard (1) is mounted to the implement to alert other motorists that the machine is traveling below posted speed limits. The SMV placard is highly reflective and must be mounted to the implement where it is easily visible to other motorists when the implement is in motion.

NOTE: Orthman rigid toolbar is shown. Orthman double bar toolbar is similar.

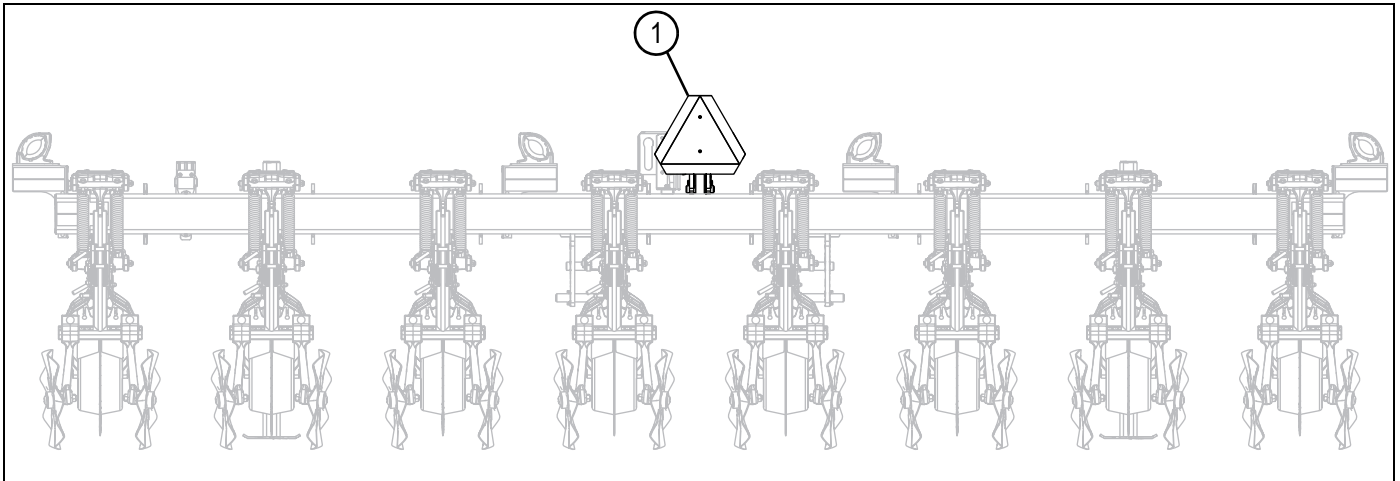

Figure 2-2

ORM000297

- 1) Slow moving vehicle (SMV) placard

No Riders

⚠ WARNING

Never allow riders on the tractor or implement. Failure to follow this information could result in death or serious injury.

Riders hinder operator visibility and can be thrown from the implement and/or be struck by foreign objects resulting in injury or death.

Prepare for Emergencies

Be prepared for a fire. Keep a readily accessible fire extinguisher at all times.

Keep a readily accessible stocked first aid kit and emergency phone numbers for your doctor, hospital, ambulance, and fire department.

Wear protective clothing and equipment. Wear clothing appropriate for the situation. Protect your eyes, ears, hands, and feet with the use of protective goggles, ear plugs, gloves, boots, etc.

Safety Never Hurts

⚠ CAUTION

Read and understand the entire contents of this manual before operating or servicing the implement.

Use the following safety practices:

- Understand all implement functions.
- Never stand between the tractor and implement when connecting or disconnecting the implement.
- Be aware of all surroundings before you move the implement.
- Operate the implement from operator's seat only.
- Never mount or dismount a moving tractor.
- Never leave the engine running when the implement is unattended.
- Keep away from power driven parts when in motion.

Make sure all personnel are clear before lowering implement to the ground.

Practice Safe Maintenance

Proper maintenance is your responsibility. Maintenance neglect and/or poor maintenance practices can result in injury or death. Always use the proper tools to maintain the implement.

DANGER

Avoid crushing. Failure to follow this information will result in death or serious injury. Make sure all personnel are clear of the implement before lowering.

Lower the implement to the ground, place the tractor in park, turn off the engine, and remove the key.

DANGER

Avoid crushing. Failure to follow this information will result in death or serious injury. Use bar stands and cylinder stops to support the implement.

Store the implement on a clean, dry, level surface. An uneven surface could cause the implement to shift or fall, resulting in injury or death as well as implement damage. Securely support all implement components that must be raised. Store the implement away from human activity.

DANGER

Avoid entanglement. Failure to follow this information will result in death or serious injury. Never lubricate or service the implement when in motion.

Keep away from power driven parts when in motion. Disengage power sources prior to maintaining the implement. Injury or death can result from contact with power driven parts when in motion.

DANGER

Avoid crushing. Failure to follow this information will result in death or serious injury. Do not stand between the tractor and implement when connecting or disconnecting the implement.

Always place the tractor in park and turn off the engine before connecting or disconnecting the implement. Injury or death can result from being trapped between the tractor and implement.

DANGER

Avoid high-pressure fluid hazards. Failure to follow this information will result in death or serious injury. Relieve hydraulic pressure before servicing or disconnecting hoses.

Escaping pressurized hydraulic fluid can penetrate the skin, resulting in injury or death. Relieve hydraulic system pressure before connecting or disconnecting the tractor.

Never use hands to check for hydraulic leaks. Use cardboard or wood. Wear protective gloves and safety glasses or goggles when working with hydraulic systems. If an accident occurs, see a doctor immediately for proper treatment.

Never operate a combustion engine in an enclosed area. Make sure there is adequate ventilation. Exhaust fumes can cause asphyxiation.

Service tires safely. Tire and rim separation can result in serious injury or death. Do not over inflate tires. Only mount or dismount tires if you possess the proper equipment, otherwise contact a trained professional. Always maintain correct tire pressure. Inspect tires and wheels daily. Do not operate tires with inadequate pressure, cuts, visible damage, or missing hardware.

CAUTION

Be extremely careful working around unshielded sharp edges. Injury may result from contact with sharp edges.

Keep all parts in good condition and properly installed. Replace damaged or missing parts immediately.

Remove tools and unused parts prior to implement operation.

Anhydrous Ammonia (NH₃) and Liquid Fertilizer

⚠ DANGER

Avoid direct exposure to anhydrous ammonia (NH₃) and liquid fertilizer. Failure to follow this information will result in death or serious injury.

Use extreme care when working with anhydrous ammonia (NH₃) and liquid fertilizer.

Keep a clean supply of water readily accessible in case of exposure to NH₃ or liquid fertilizer.

Wear protective goggles and gloves when working with NH₃ or liquid fertilizer. Be sure all persons involved in the operation are properly trained concerning the dangers and precautions involved in the application of NH₃ or liquid fertilizer.

If you choose to apply NH₃ or liquid fertilizer, it is advisable to consult documented information regarding safe handling and application of NH₃ or liquid fertilizer. Information is available from the following recognized sources:

- American National Standards Institute (ANSI): www.ansi.org - (212) 642-4900
- Material Safety Data Sheets (MSDS): www.msdsolnline.com
- National Safety Council: www.nsc.org/necas
- The Fertilizer Institute: www.tfi.org
- United States Department of Transportation (USDOT): www.dot.gov
- Compressed Gas Association: www.cganet.com

Orthman Serial Number Plate

The Orthman serial number plate contains valuable information. The model number (1) and serial number (2) provide Orthman dealers and the Orthman service department with the exact specifications of your implement if any warranty or service issues need to be addressed. The serial number plate can be found on the Orthman toolbar, and is usually located at the end of the wing or on the wing fold linkage.

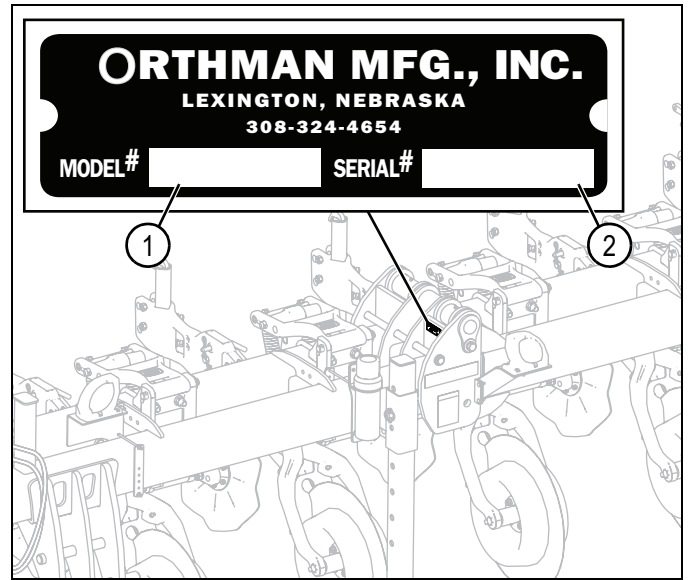

ORM000294

Figure 2-3: Double Folding Toolbar

- 1) Model number 2) Serial number

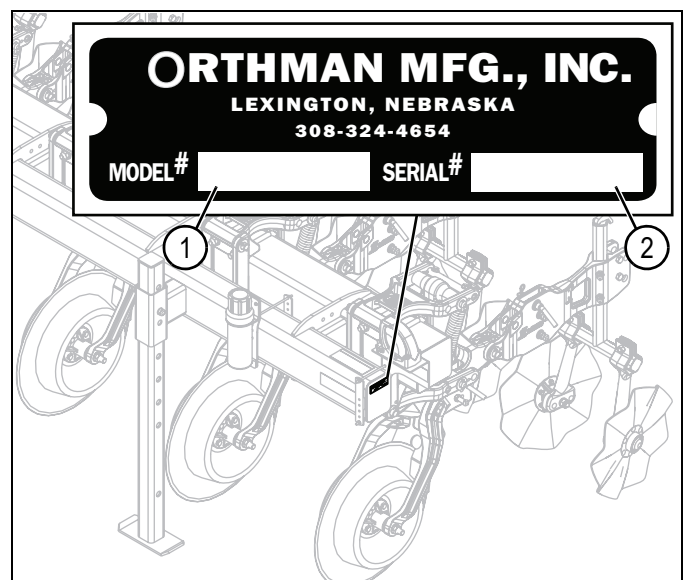

ORM000295

Figure 2-4: Rigid Toolbar

- 1) Model number 2) Serial number

Safety Decals

Safety decals promote awareness and knowledge concerning safe operation and maintenance of the implement. Carefully read all safety decals in this manual as well as on the implement.

Keep the implement clean so decals are easily visible. Keep all decals in good, legible condition. Immediately replace damaged and/or missing decals.

Orthman Right Side Decals

NOTE: Orthman double bar toolbar is shown. Orthman rigid toolbar is similar.

See the Orthman toolbar operator manual for proper placement of safety decals.

NOTE: Replacement decals are available from your Orthman dealer. When replacing decals, thoroughly clean the area where the decal is to be placed and attach the decal void of bubbles.

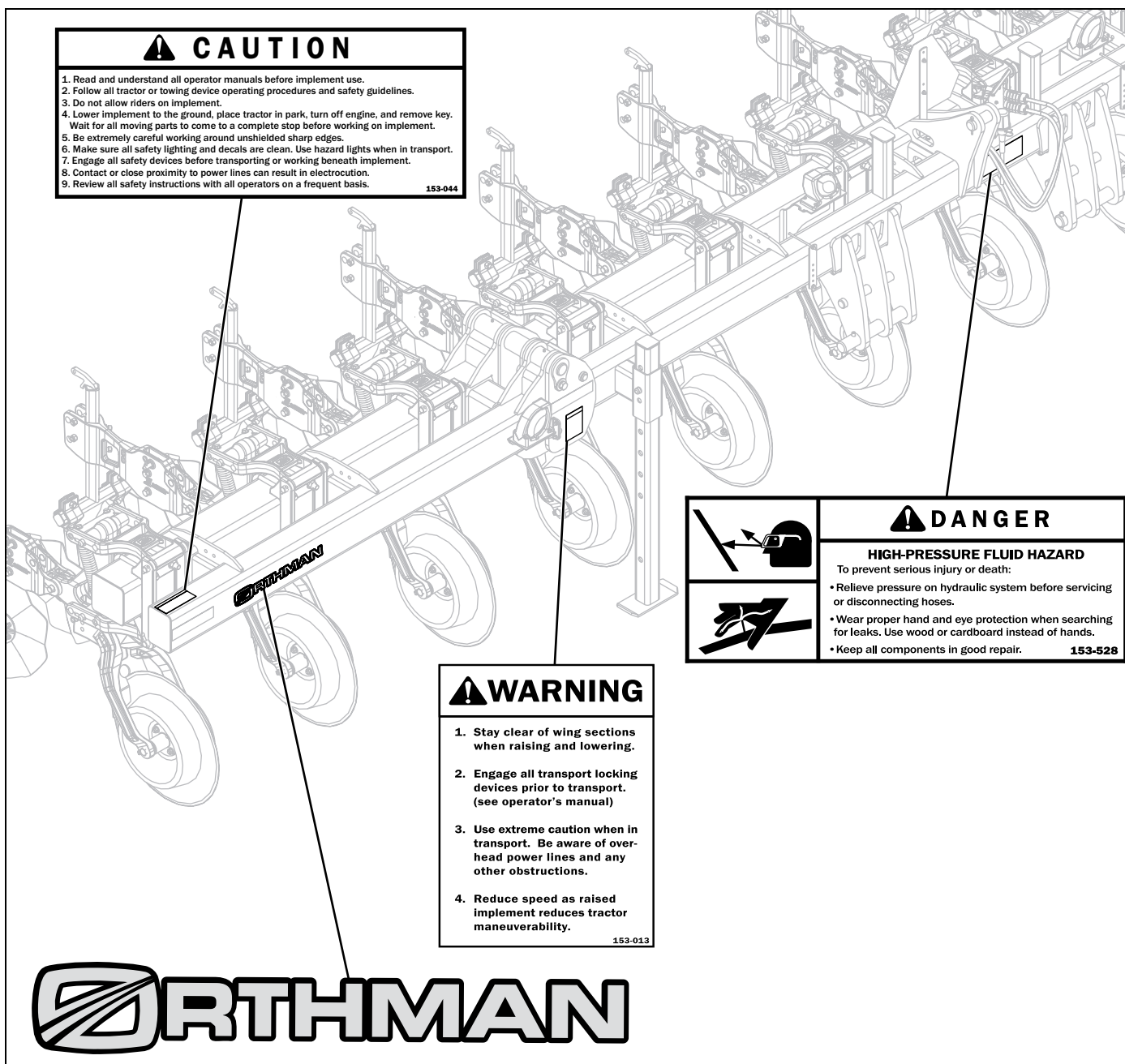

Figure 2-5

ORM000250

Orthman Left Side Decals

NOTE: Orthman double bar toolbar is shown. Orthman rigid toolbar is similar.

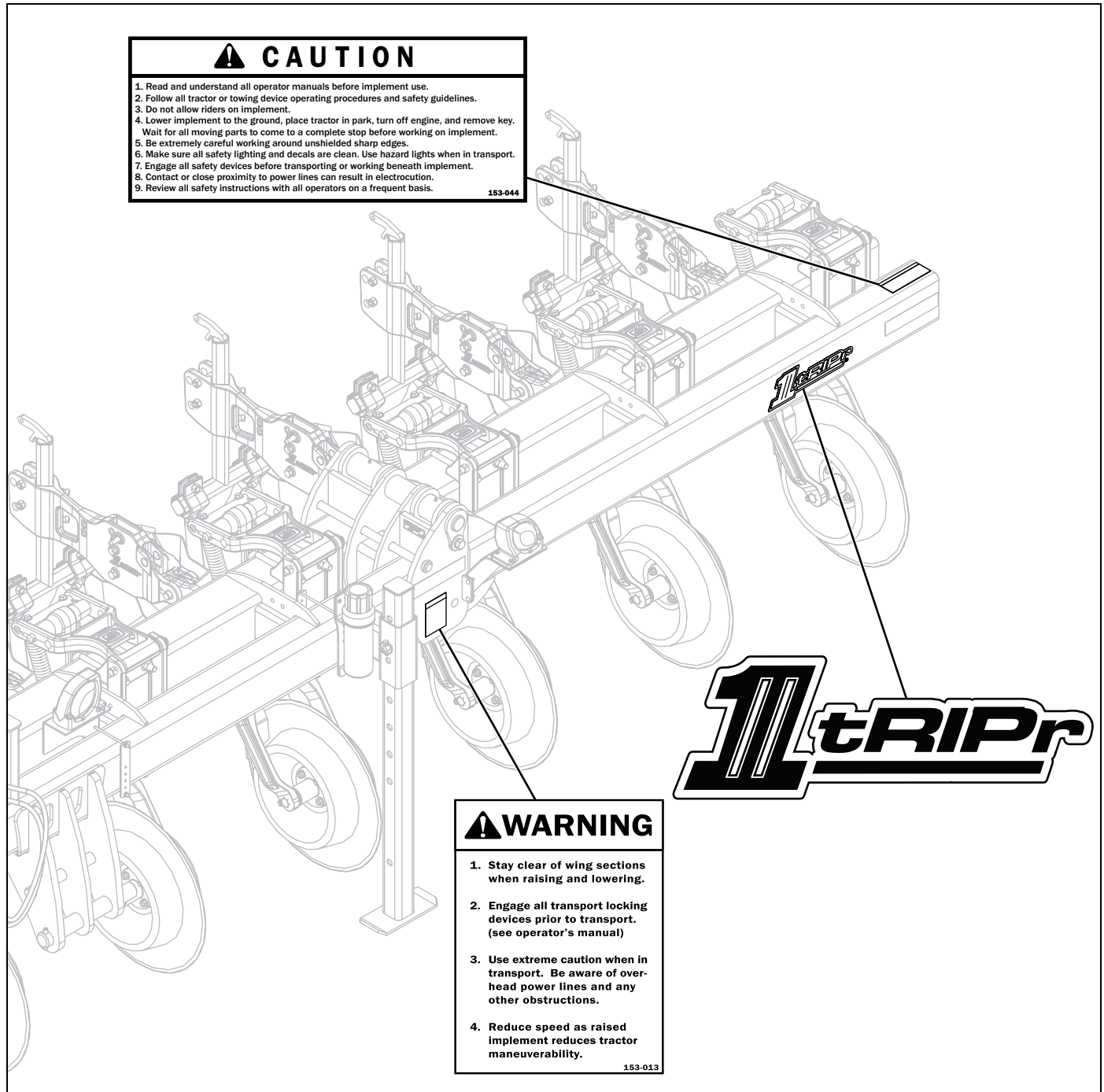

Figure 2-6

ORM000296

Page Intentionally Blank

Chapter 3

Major Components

Main Frame	3-2
Tail Section	3-3
Rolling Basket Assembly	3-4
Coastal Plains Roller Assembly	3-5

Main Frame

NOTE: The rigid row cleaner assembly (6) is shown.
The floating row cleaner assembly is similar.

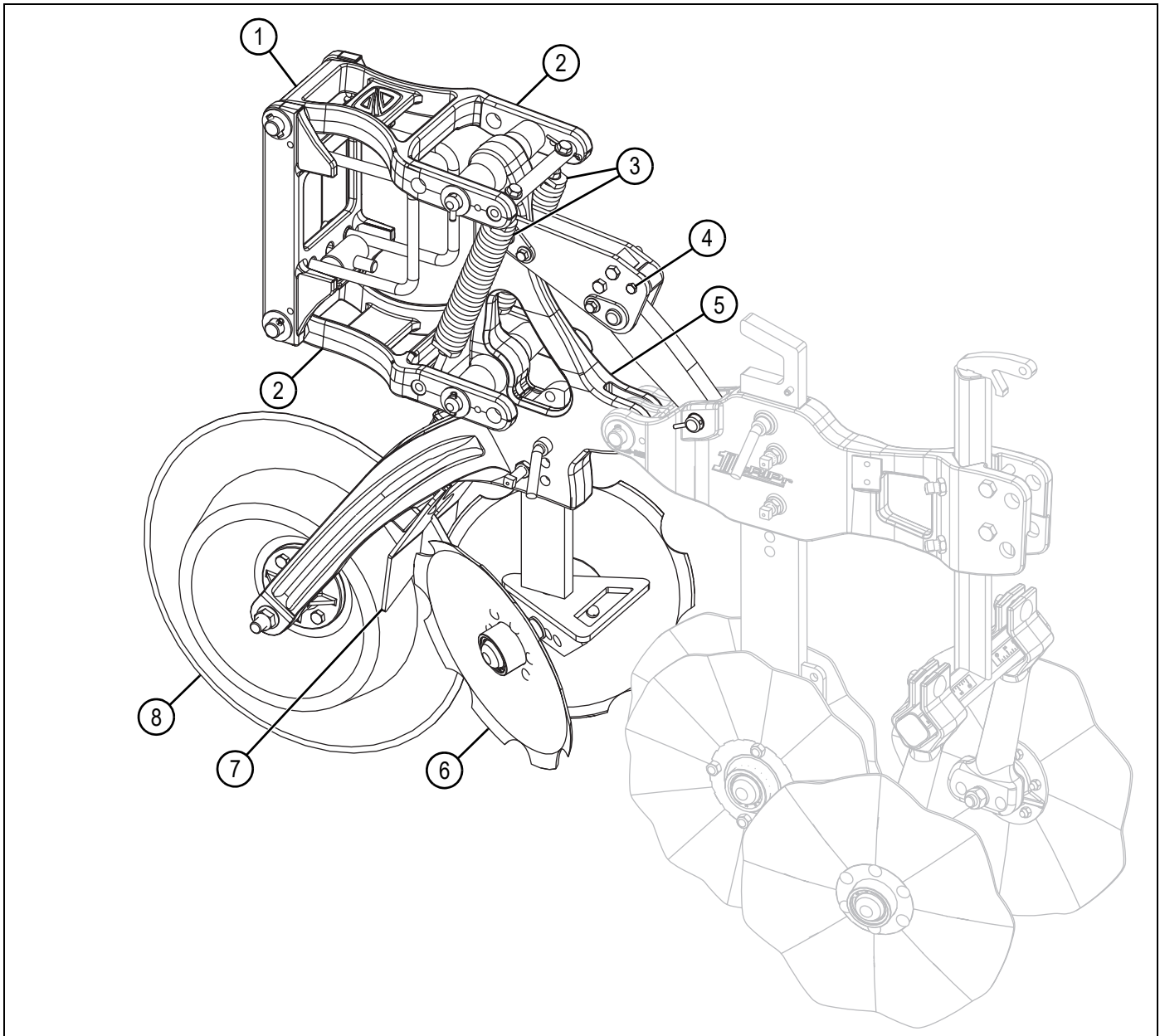

Figure 3-1

ORM000251

- | | |
|----------------------------------|--------------------------------|
| 1) Toolbar mount | 5) Main frame |
| 2) Parallel linkage (2 used) | 6) Row cleaner assembly |
| 3) Down pressure spring (2 used) | 7) Scraper |
| 4) Shear bolt | 8) Depth band coulter assembly |

Tail Section

NOTE: The dry fertilizer 2 inch boot tillage shank assembly (2) is shown. The liquid fertilizer boot, dry fertilizer 1.5 inch boot, shallow tillage shank, mole knife shank, and AA knife shank assemblies are similar.

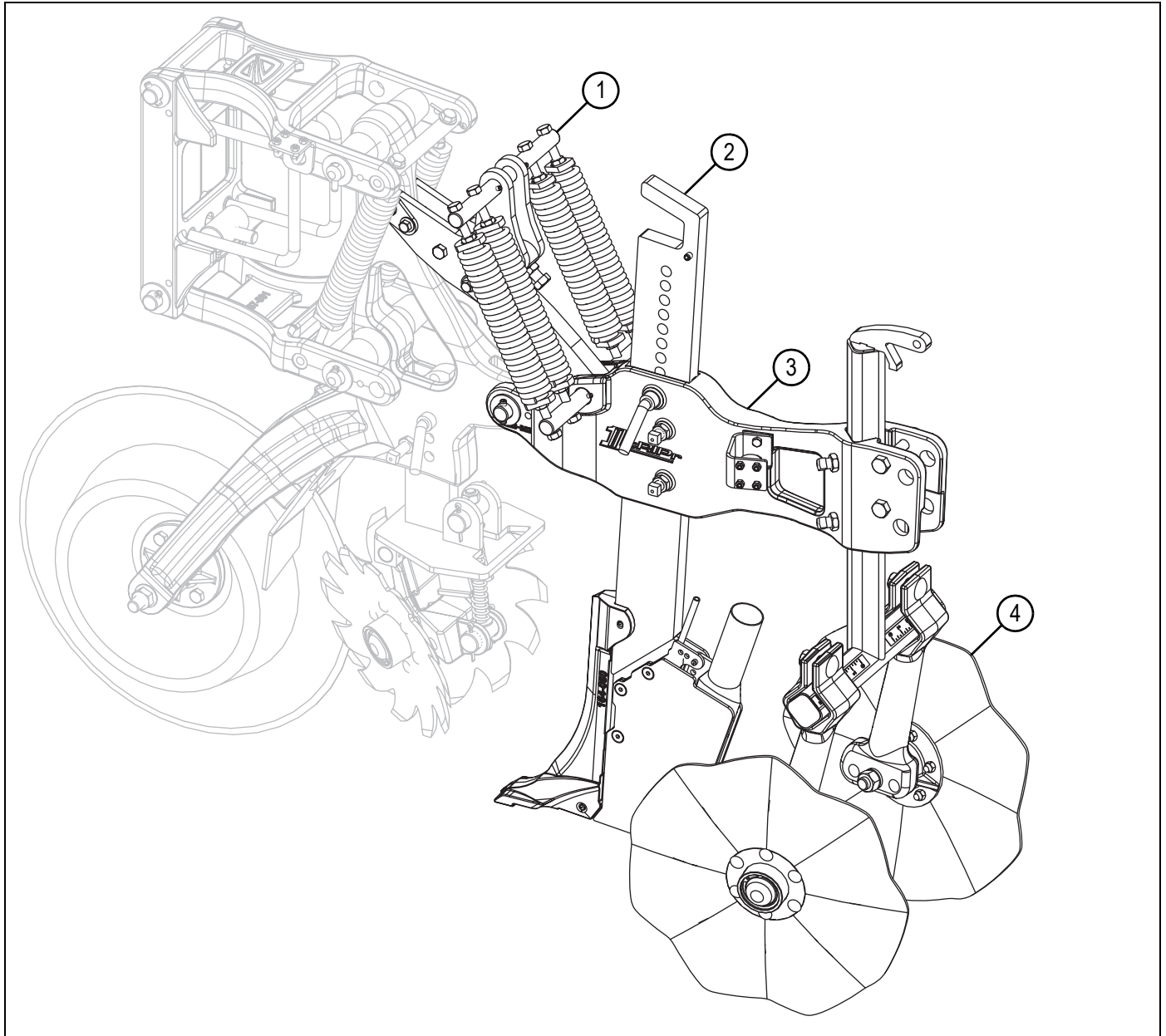

Figure 3-2

ORM000252

- 1) Auto-reset (AR) trip linkage (optional)
- 2) Tillage shank assembly

- 3) Tail section
- 4) Wavy coulter assembly

Rolling Basket Assembly

NOTE: The 14 inch berm-promoting rolling basket is shown. The 14 inch standard, 8 inch narrow standard, and 10 inch vertical tillage rolling baskets are similar.

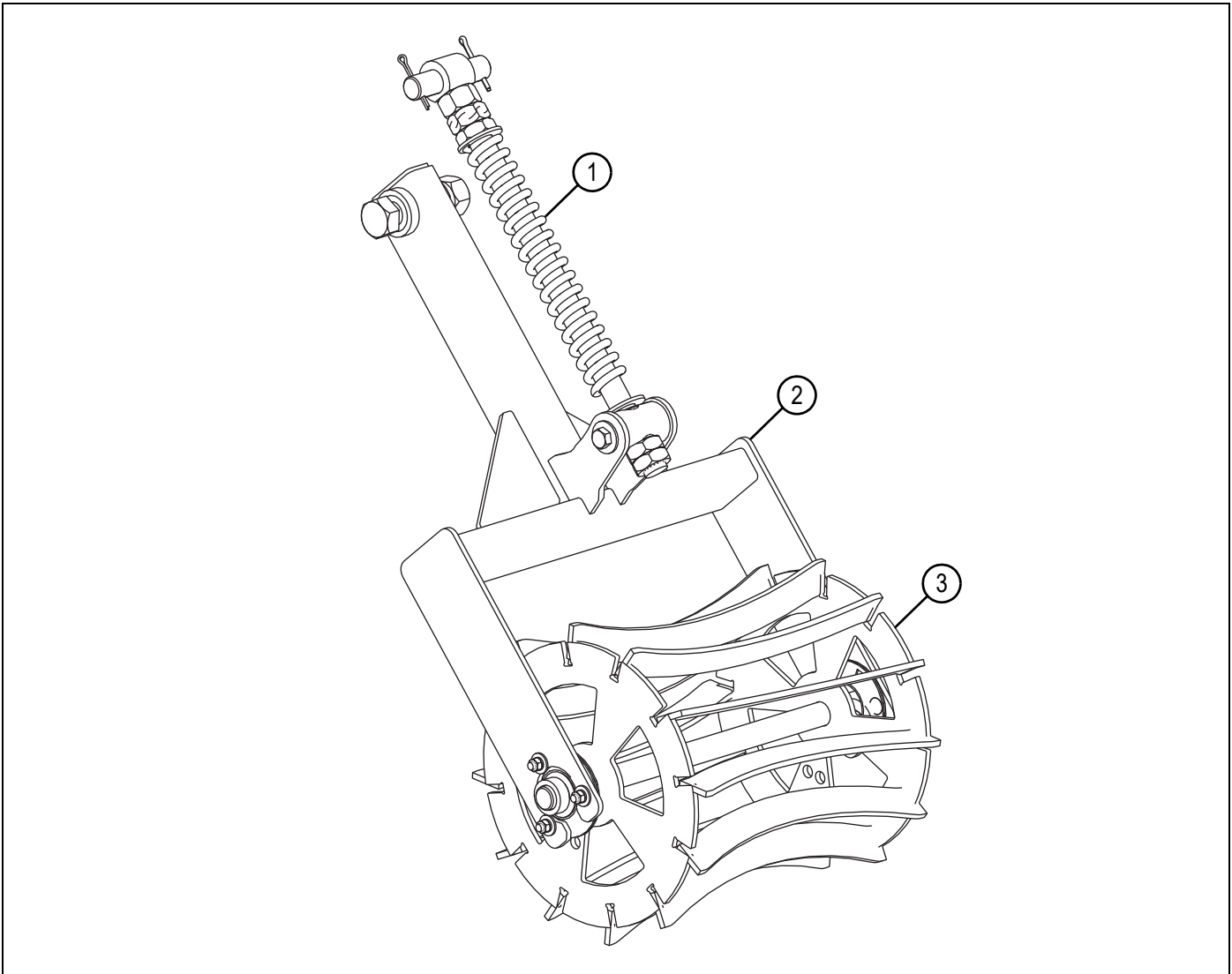

Figure 3-3

ORM000058

1) Spring

2) Basket frame

3) Basket

Coastal Plains Roller Assembly

NOTE: The 12.5 inch coastal plains roller is shown.
The 20 inch coastal plains roller is similar.

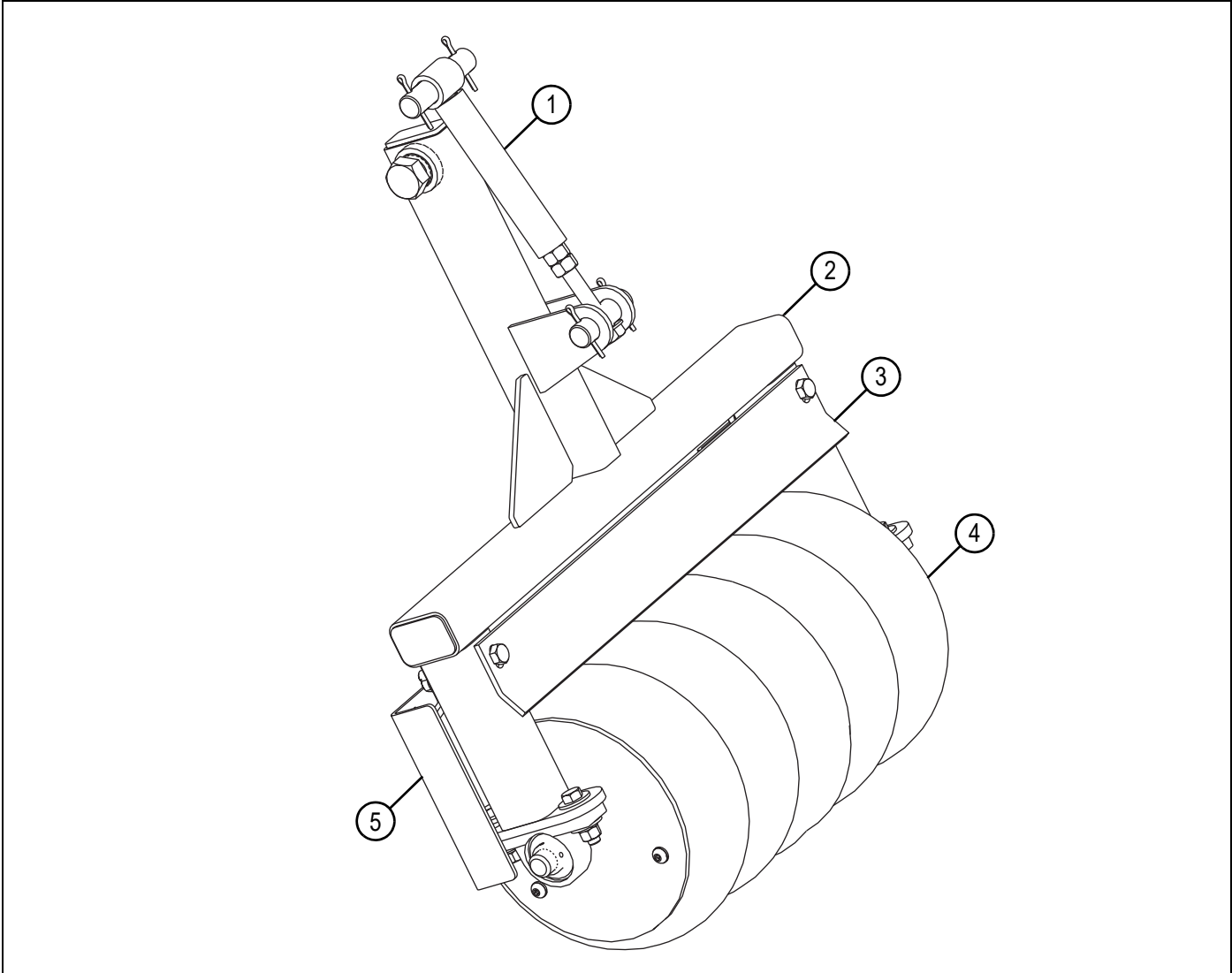

Figure 3-4

ORM000255

- 1) Turnbuckle
- 2) Roller frame

- 3) Scraper
- 4) Roller

- 5) Guard

Page Intentionally Blank

Chapter 4

Preparation and Setup

Shipping Configuration	4-2
Preparing the 1tRIPr® II Row Unit	4-3
Implement-to-Tractor Connection	4-3
Tooling Options	4-4
Individual Row Units	4-4
Mounting Row Unit	4-4
Row Unit Set-Back Clamp	4-6
Mounting Set-Back Clamp	4-6
Rolling Basket Assembly	4-8
Rolling Basket Assembly Installation	4-8
Tillage Shank	4-9
Shallow Tillage Assembly	4-9
Liquid Fertilizer Mole Shank Assembly	4-9
Mole Knife Assembly	4-10
AA Knife Assembly	4-10
Dry Mole Shank Assembly	4-11
Air Diffuser Installation	4-11
Tillage Shank Installation	4-12
Mole Shank Assembly Fertilizer Tube Installation	4-13
Mole Knife Assembly Fertilizer Tube Installation	4-14
Dry Mole Shank Assembly Fertilizer Tube and Dry Boot Installation	4-15
Mole Shank Shin Cap Installation	4-16
Automatic Reset (AR) Trip Linkage Installation	4-17

Shipping Configuration

The 1tRIPr® II Row Unit is assembled in an appropriate shipping configuration to ensure transport safety and efficiency from the manufacturer. The shipping configuration provides even implement weight distribution between the depth band coulters assembly (1) and the wavy coulters assembly (4). The row cleaner assembly (2) and the tillage shank assembly (3) do not bear implement weight.

The 1tRIPr® II does not come set for field use from the factory. Installation of optional tooling (if applicable) and adjustment of installed tooling is necessary prior to an initial field trial. Please refer to “Operation and Field Settings” for proper settings.

Prior to off-season storage, it is recommended to restore the 1tRIPr® II Row Units to the shipping configuration to avoid placing weight on the row cleaner or tillage shank assembly. For more information on implement storage, see “Implement Storage” on page 7-4.

⚠ DANGER

Avoid crushing. Failure to follow this information will result in death or serious injury. Make sure all personnel are clear of the implement before lowering.

⚠ CAUTION

- Be extremely careful working around unshielded sharp edges. Injury may result from contact with sharp edges.
- Avoid implement damage. The tillage shank assembly foot piece consists of a hard material to decrease wear and improve field performance. Damage to the tillage shank assembly foot piece can occur due to material hardness, sharp impact, excessive weight, etc.

When storing in-season, lower implement very slowly to avoid sharp impact between the storage surface and the tillage shank assembly foot piece.

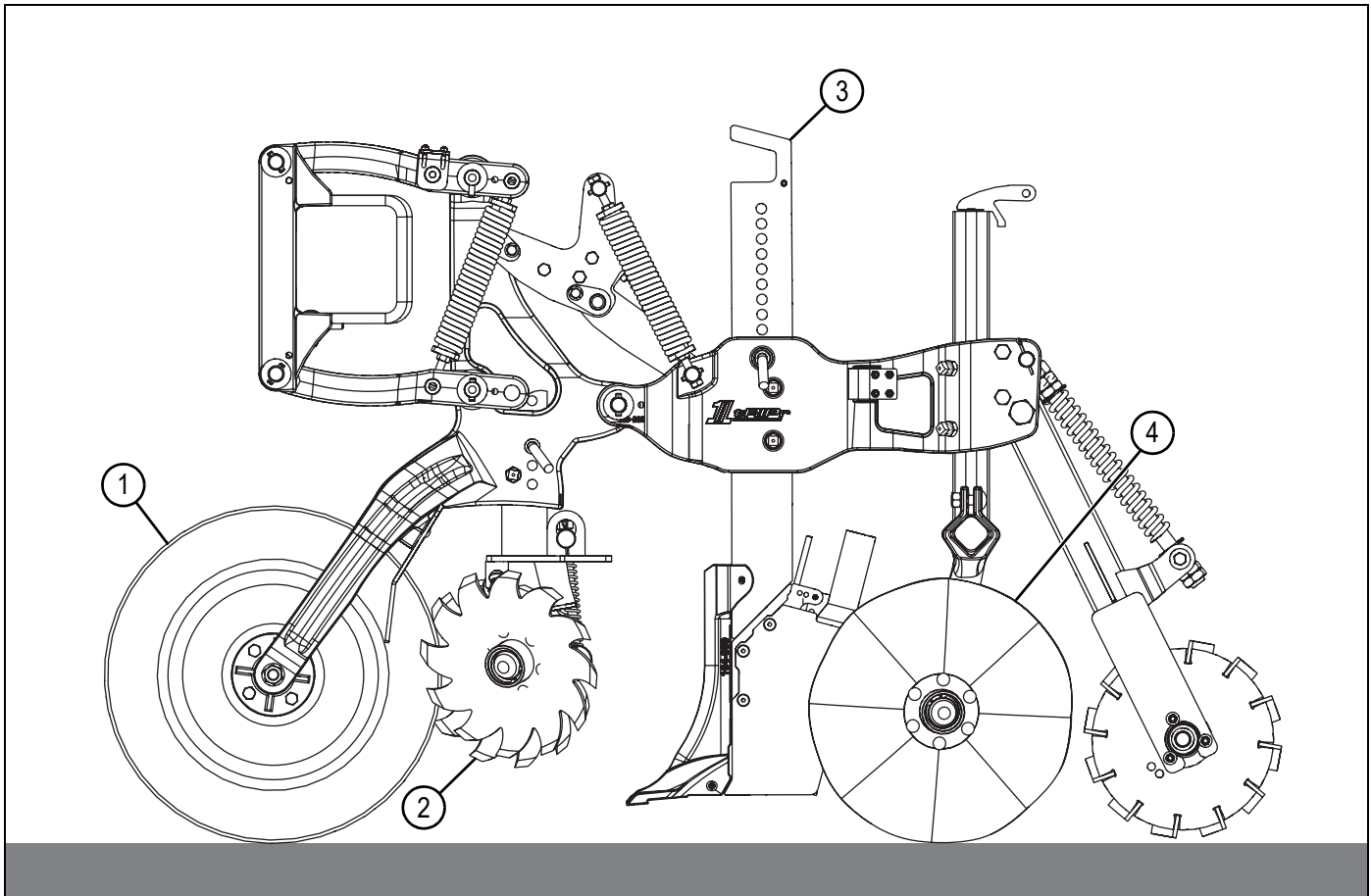

Figure 4-1

ORM000256

- 1) Depth band coulters assembly 2) Row cleaner assembly 3) Tillage shank assembly 4) Wavy coulters assembly

Preparing the 1tRIPr® II Row Unit

1. Read and understand the operator's manual for all tooling options used in conjunction with the 1tRIPr® II Row Units. See "Tooling Options" on page 4-4.
2. Make all necessary tooling adjustments prior to field use. See "Field Adjustments" on page 5-4.
3. If an Orthman toolbar is used in conjunction with 1tRIPr® II Row Units, be sure to consult the toolbar operator's manual before attempting to operate the implement. Read and understand the operator manuals for all machinery used in conjunction with the 1tRIPr® II.
4. Make sure that all decals are in good, clean, and legible condition. Make sure each decal is correctly placed according to the safety section of this operator's manual. See "" on page 2-9 for more information.
5. Be sure to lubricate all grease points on machine. See "Lubrication" on page 7-4.
6. Before each use, check all hardware for wear and the proper torque. Replace missing hardware with hardware of an identical grade in order to restore the implement to original specifications. See "Implement Inspection" on page 7-4.

Implement-to-Tractor Connection

DANGER

Avoid crushing. Failure to follow this information will result in death or serious injury. Make sure all personnel are clear of the implement before lowering.

DANGER

Avoid crushing. Failure to follow this information will result in death or serious injury. Do not stand between the tractor and implement when connecting or disconnecting the implement.

DANGER

Avoid crushing. Failure to follow this information will result in death or serious injury. Use bar stands and cylinder stops to support the implement.

Store the implement on a clean, dry, level surface. An uneven surface could cause the implement to shift or fall, resulting in injury or death as well as implement damage. Securely support all implement components that must be raised.

If an Orthman toolbar is used in conjunction with 1tRIPr® II Row Units, be sure to consult the toolbar operator's manual for implement-to-tractor connection procedures.

See the tractor operator's manual for more information on properly connecting the implement.

Tooling Options

Individual Row Units

In most cases the 1tRIPr® II is purchased as a machine and row units are factory installed to the toolbar. Individual 1tRIPr® II Row Units can be purchased separate of a toolbar.

Mounting Row Unit

See Figure 4-2 on page 4-5.

Tools
• 1-1/8 in Wrench
• 1-1/8 in Impact socket
• Impact wrench

DANGER

Avoid crushing. Failure to follow this information will result in death or serious injury. Make sure all personnel are clear of the implement before lowering.

DANGER

Avoid crushing. An uneven surface could cause the implement to shift or fall, resulting in injury or death as well as implement damage. Park the implement on a clean, dry, level surface.

DANGER

Avoid crushing. Failure to follow this information will result in death or serious injury. Use bar stands and cylinder stops to support the implement.

1. Lower the implement to the ground, place the tractor in park, turn off the engine, and remove the key.

2. Remove buildup of grease, oil, and debris prior to installing row unit mounts. See “Implement Inspection” on page 7-4.
3. Remove mount (3) from front of parallel linkage (5) of row unit (6).
4. Leave wedge bolt (1) installed. Slightly start wedge bolt threads into wedge (8) and position on toolbar (7).
5. Install U-bolts (4) and locking nuts (2) until mount is secure on toolbar.
6. Tighten wedge bolt until wedge moves up the ramp and becomes tight against the bottom of the toolbar.

NOTE: *Mount ears should come tight against top of toolbar at this time. If mount ears do not come tight against top of toolbar, loosen U-bolts slightly and retry.*

7. Finish tightening U-bolt locking nuts evenly.

NOTE: *U-bolt nuts are locking nuts and may tighten slowly.*

8. Install row unit parallel linkage to mount. When properly installed, mount should be square and top ears of mount should both contact top side of toolbar.
9. After initial break-in period of field operation, check all hardware for tightness.

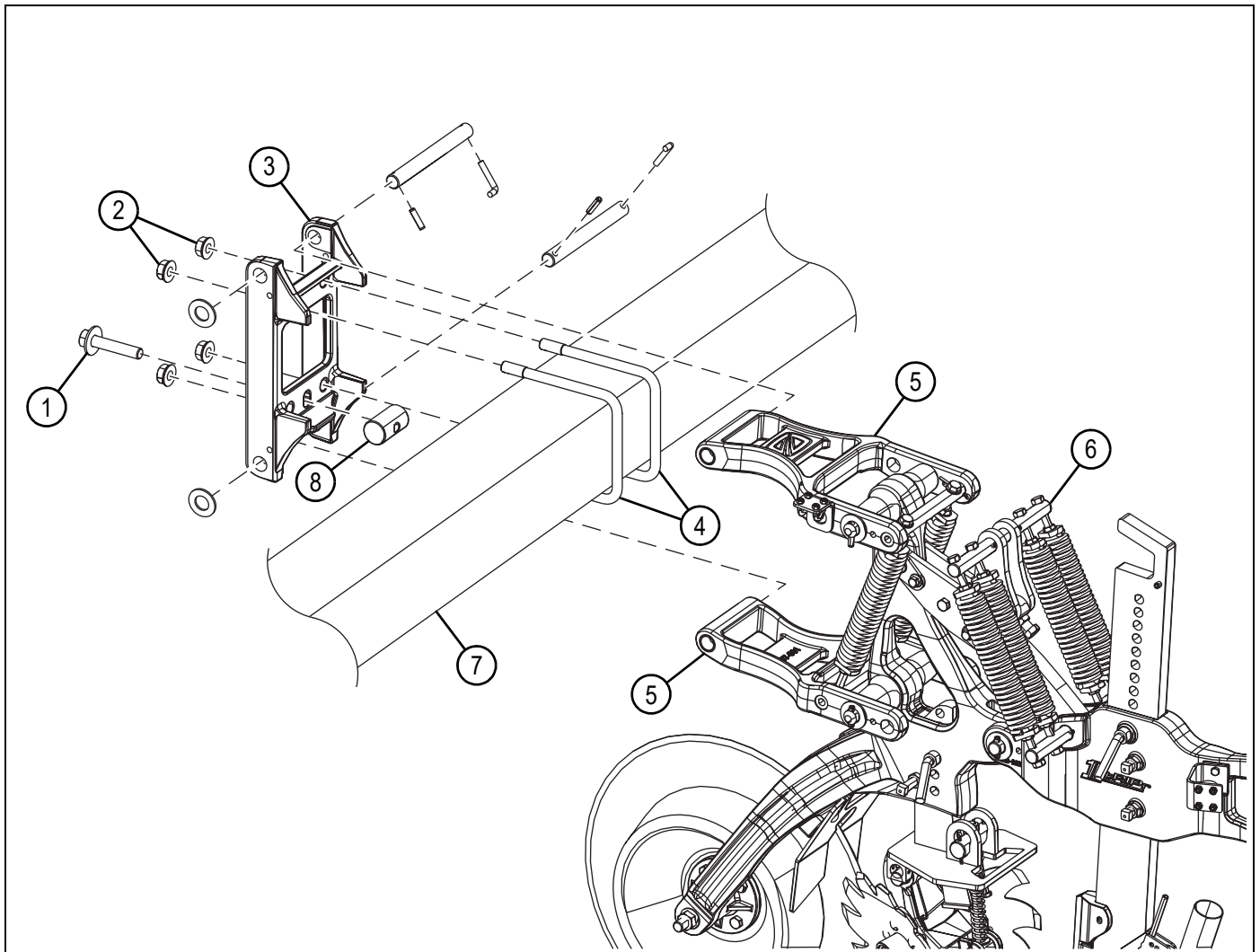

ORM000257

Figure 4-2

- | | | | |
|-------------------------|--------------------|------------------------------|------------|
| 1) Wedge bolt | 3) Mount | 5) Parallel linkage (2 used) | 7) Toolbar |
| 2) Locking nut (4 used) | 4) U-bolt (2 used) | 6) Row unit | 8) Wedge |

Row Unit Set-Back Clamp

Row unit set-back clamps are recommended on 1tRIPr® II machines set at 22 inch row spacing and become necessary on machines set at 20 inch row spacing. Row unit set-back clamps are typically installed on every other row unit across the machine.

Mounting Set-Back Clamp

See Figure 4-3 on page 4-7.

Tools
• 1-1/8 in Wrench
• 1-1/8 in Impact socket
• Impact wrench
• 3/4 in Washer (as needed)

DANGER

Avoid crushing. Failure to follow this information will result in death or serious injury. Make sure all personnel are clear of the implement before lowering.

DANGER

Avoid crushing. An uneven surface could cause the implement to shift or fall, resulting in injury or death as well as implement damage. Park the implement on a clean, dry, level surface.

DANGER

Avoid crushing. Failure to follow this information will result in death or serious injury. Use bar stands and cylinder stops to support the implement.

1. Lower the implement to the ground, place the tractor in park, turn off the engine, and remove the key.
2. Remove buildup of grease, oil, and debris prior to installing row unit mounts. See “Implement Inspection” on page 7-4.
3. Remove row unit from traditional mount at front of parallel linkage. See “Mounting Row Unit” on page 4-4.
4. Install row unit set-back clamp (1) and hand tighten clamp bolts (4).
5. Use adjustment bolts (3) and washers (as needed) (5) to set the hole to hole distance of 14 in (35.7 cm) (6).
6. Tighten set-back clamp bolts and adjustment bolts to proper torque. See “Torque Specifications” on page 7-2.
7. Install row unit parallel linkage (2) to set-back clamp.

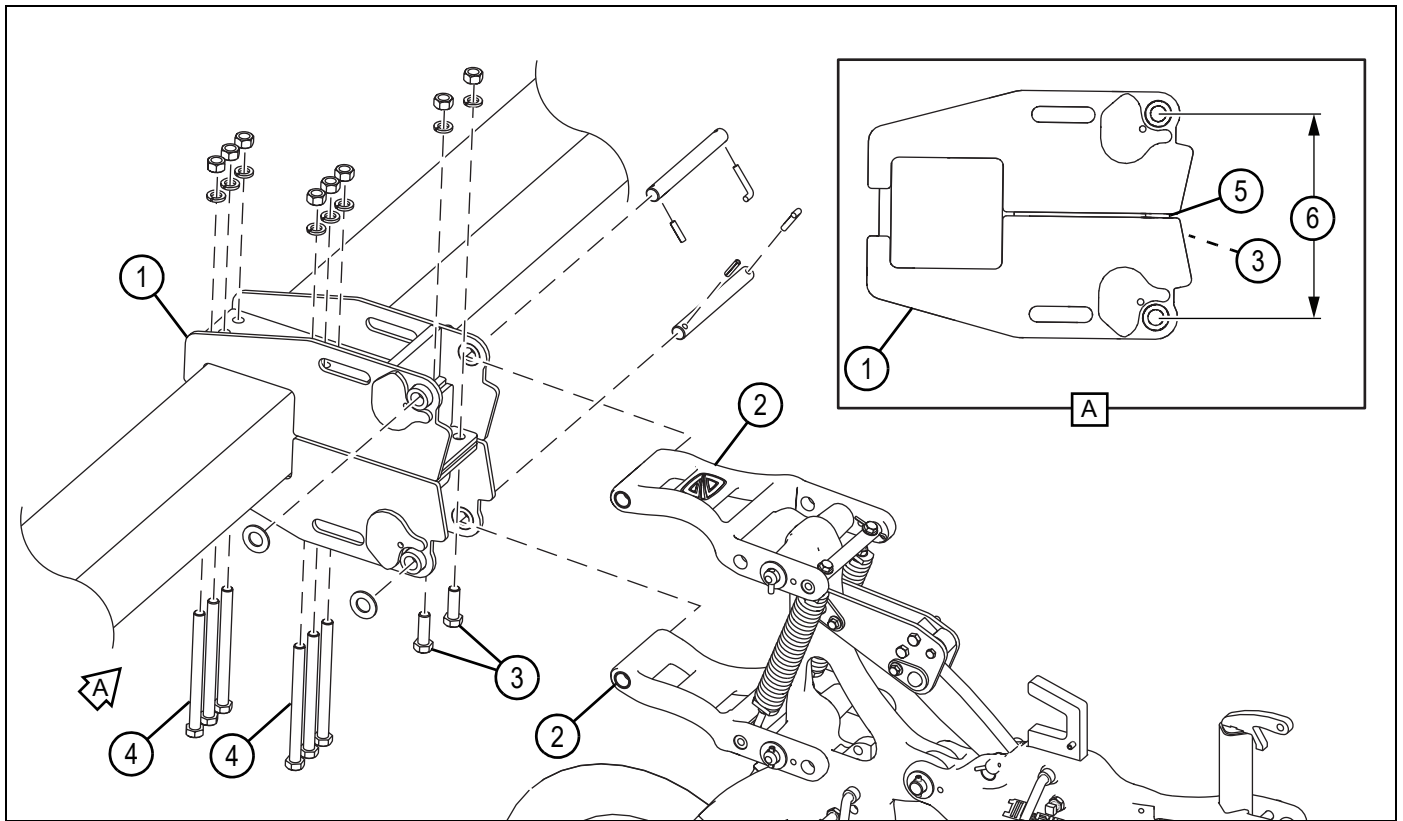

ORM00528

Figure 4-3

- | | | |
|------------------------------|-----------------------------|-------------------------------------|
| 1) Set-back clamp | 3) Adjustment bolt (2 used) | 5) Washer (as needed) |
| 2) Parallel linkage (2 used) | 4) Bolt (6 used) | 6) Hole distance of 14 in (35.7 cm) |

Rolling Basket Assembly

The rolling basket assembly is an option that features adjustable down pressure to help break up remaining clods and ensure smooth 1tRIPr® II operation. The rolling basket is mounted to the rear of the row unit tail section.

NOTE: Due to clearance issues, rolling baskets cannot be used in conjunction with certain planter attachment packages. A lift assist wheel extension package is available to utilize rolling baskets and lift assist wheels simultaneously. Contact your Orthman dealer for lift assist wheel extension package information to alleviate clearance issues.

Rolling Basket Assembly Installation

Tool
<ul style="list-style-type: none">1-1/2 in Socket or wrench

⚠ DANGER

Avoid crushing. Failure to follow this information will result in death or serious injury. Make sure all personnel are clear of the implement before lowering.

⚠ DANGER

Avoid crushing. An uneven surface could cause the implement to shift or fall, resulting in injury or death as well as implement damage. Park the implement on a clean, dry, level surface.

⚠ DANGER

Avoid crushing. Failure to follow this information will result in death or serious injury. Use bar stands and cylinder stops to support the implement.

1. Lower the implement to the ground, place the tractor in park, turn off the engine, and remove the key.
2. Remove buildup of grease, oil, and debris prior to installing row unit mounts. See "Implement Inspection" on page 7-4.

⚠ CAUTION

Be extremely careful working around unshielded sharp edges. Injury may result from contact with sharp edges.

3. Remove nut (2) and bolt (5) from basket frame (4).
4. Align tail section (1) and basket frame bolt holes.
5. Install nut and bolt and tighten to proper torque specifications. See "Torque Specifications" on page 7-2.
6. Remove cotter pins (7) and pin (6) from the spring assembly (3).
7. Align tail section and spring assembly pin holes.
8. Install pin and cotter pins.

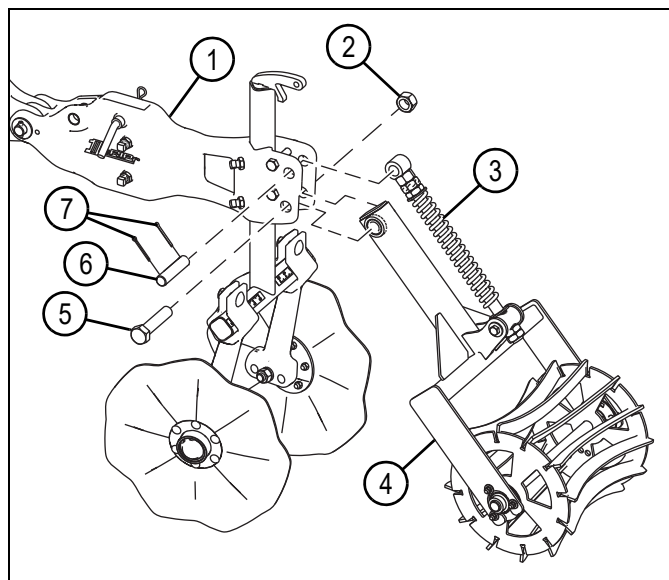

Figure 4-4

ORM000254

- | | |
|--------------------|------------------------|
| 1) Tail section | 5) Bolt |
| 2) Nut | 6) Pin |
| 3) Spring assembly | 7) Cotter pin (2 used) |
| 4) Basket frame | |
9. Adjust rolling basket down pressure as needed. See "Rolling Basket Down Pressure" on page 5-11.

Tillage Shank

The tillage shank shatters compaction, eliminates subsoil voids, increases water infiltration, and promotes vigorous root growth through all stages of seed development. The tillage shank assembly is integral in achieving all three of the following principals of strip-till planting: Ideal Seedbed Preparation, Precision Nutrient Placement, and Optimal Root-Zone Conditioning.

Various tillage shank options are available:

- Shallow tillage assembly
- Liquid fertilizer mole shank assembly
- 12 inch mole knife assembly
- AA knife assembly
- Dry mole shank assembly

If combining strip-tillage and planting operations with a Combo Caddy or attachment package, lateral offset of the 1tRIPr® II Row Unit relative to seed placement is recommended to allow fertilizer placement without detriment to seed germination.

For tillage shank assembly installation instructions, see “Tillage Shank Installation” on page 4-12.

Shallow Tillage Assembly

The shallow tillage assembly is a lower disturbance option that aids in Seedbed Preparation.

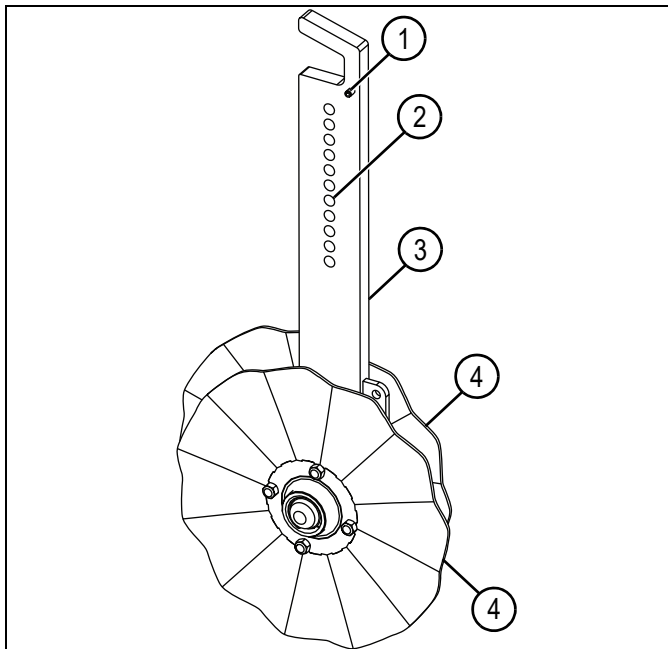

Figure 4-5

ORM000275

- | | |
|-------------------------------------|-------------------------|
| 1) Roll pin | 3) Shank |
| 2) Height adjustment hole (11 used) | 4) Wavy couler (2 used) |

For tillage shank depth settings, see “Tillage Shank Depth Adjustment Chart” on page 5-12.

Liquid Fertilizer Mole Shank Assembly

Two adjustable liquid fertilizer tubes (4) allow precision fertilizer placement at two separate depths while being protected by hard-surfaced plates. Precision fertilizer placement provides crop plants with timely fertilizer access to maximize development from germination through maturity.

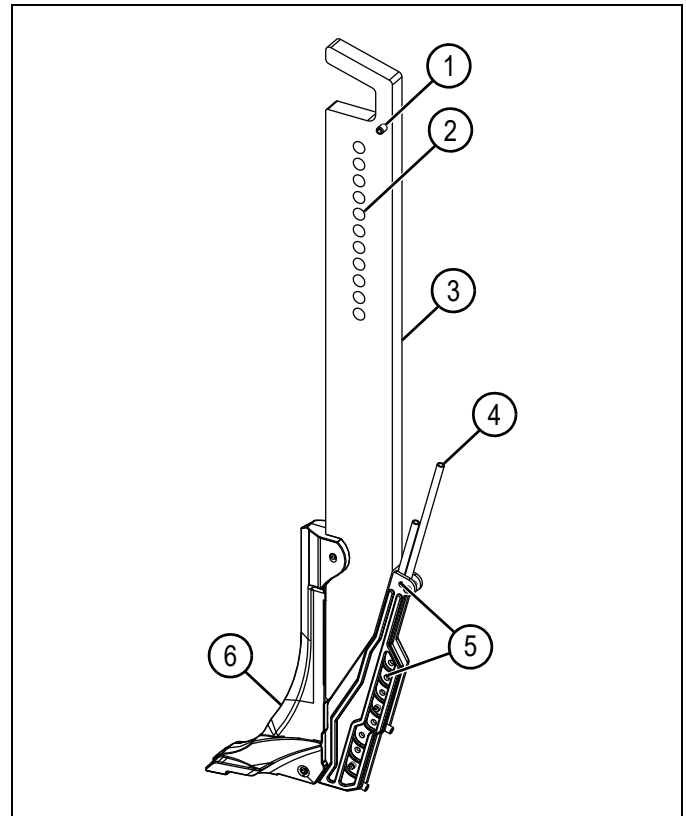

Figure 4-6

ORM000272

- | | |
|-------------------------------------|------------------------------------|
| 1) Roll pin | 4) Liquid fertilizer tube (2 used) |
| 2) Height adjustment hole (11 used) | 5) Pin hole (9 used) |
| 3) Shank | 6) Foot piece |

For liquid fertilizer tube installation, see “Mole Shank Assembly Fertilizer Tube Installation” on page 4-13.

For liquid fertilizer tube adjustments, see “Adjustable Liquid Tubes” on page 5-18.

For tillage shank depth settings, see “Tillage Shank Depth Adjustment Chart” on page 5-12.

Mole Knife Assembly

The mole knife assembly is a lower disturbance option of strip-till planting. Precision fertilizer placement provides crop plants with timely fertilizer access to maximize development from germination through maturity.

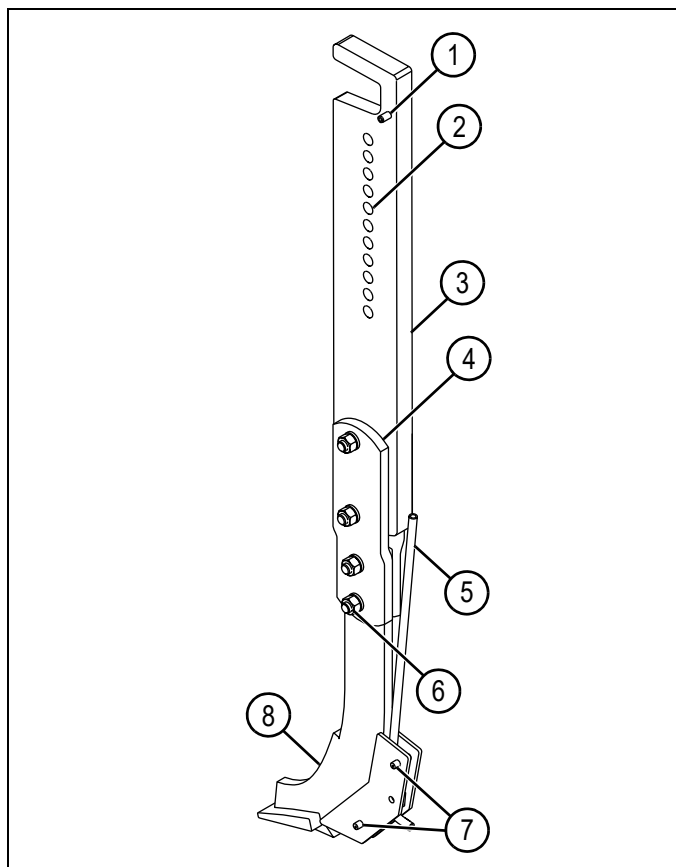

Figure 4-7

ORM000303

- | | |
|--|---------------------------|
| 1) Roll pin | 5) Liquid fertilizer tube |
| 2) Height adjustment hole
(11 used) | 6) Shear bolt |
| 3) Shank | 7) Roll pin (2 used) |
| 4) Fertilizer knife clamp
(2 used) | 8) Mole knife |

For tillage shank depth settings, see “Tillage Shank Depth Adjustment Chart” on page 5-12.

AA Knife Assembly

The liquid fertilizer tube allows for precise fertilizer placement as deep as the knife. Precision fertilizer placement provides crop plants with timely fertilizer access to maximize development from germination through maturity.

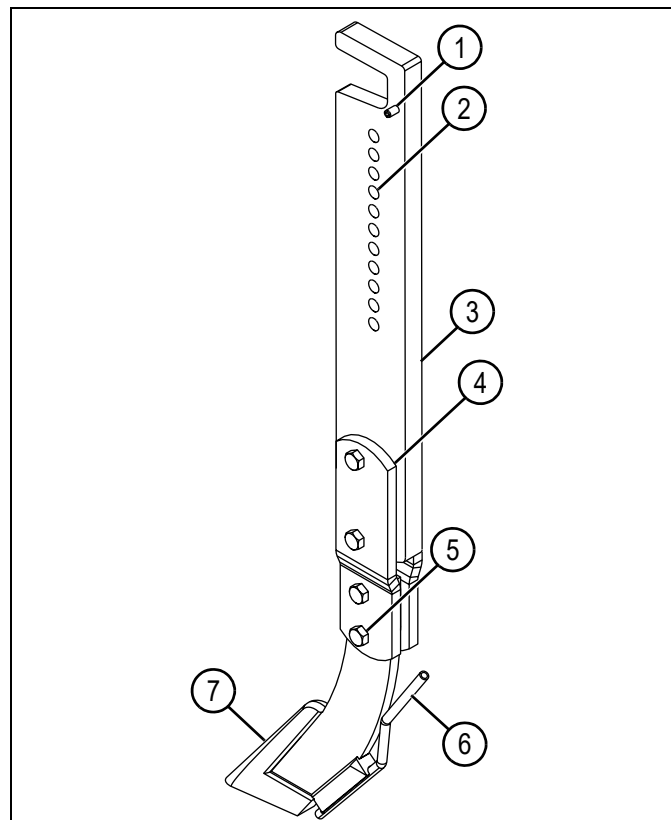

Figure 4-8

ORM000302

- | | |
|--|---------------------------|
| 1) Roll pin | 5) Shear bolt |
| 2) Height adjustment hole
(11 used) | 6) Liquid fertilizer tube |
| 3) Shank | 7) AA knife |
| 4) Fertilizer knife clamp
(2 used) | |

For tillage shank depth settings, see “Tillage Shank Depth Adjustment Chart” on page 5-12.

Dry Mole Shank Assembly

An adjustable dry fertilizer boot (5) can be used in combination with an adjustable liquid fertilizer tube (4), protected by a replaceable wear plate (6) on each side, allow diverse, precision fertilizer placement at separate depths. Boot options available in 1.5 inch or 2 inch.

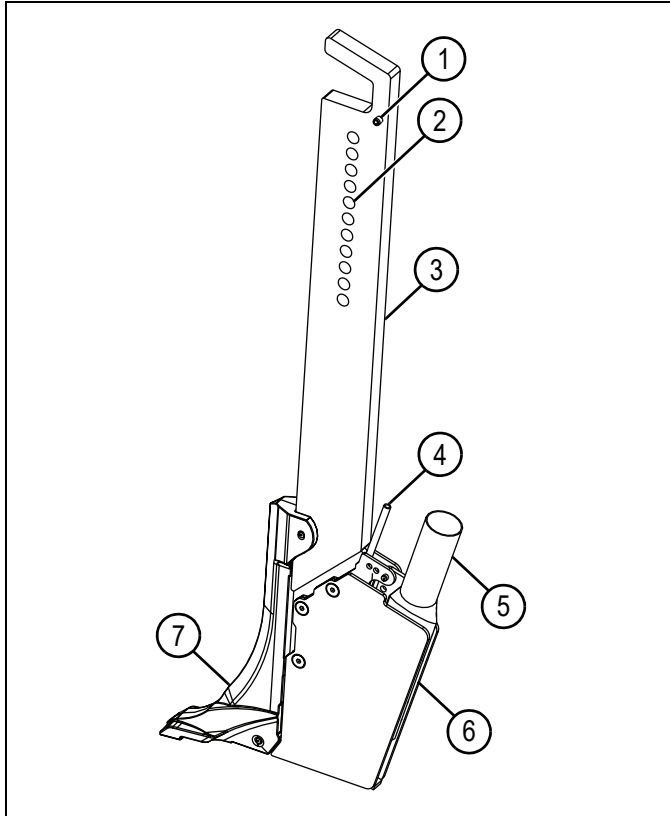

Figure 4-9: Boot (2 inch)

ORM000274

- | | |
|-------------------------------------|------------------------------------|
| 1) Roll pin | 5) Dry fertilizer boot |
| 2) Height adjustment hole (11 used) | 6) Replaceable wear plate (2 used) |
| 3) Shank | 7) Foot piece |
| 4) Liquid fertilizer tube | |

For liquid fertilizer tube and boot installation, see “Mole Shank Assembly Fertilizer Tube Installation” on page 4-13 and see “Dry Mole Shank Assembly Fertilizer Tube and Dry Boot Installation” on page 4-15.

For liquid fertilizer tube and dry boot adjustments, see “Adjustable Liquid Tubes” on page 5-18 and see “Adjustable Dry Fertilizer Boot on Dry Mole Shank” on page 5-19.

For tillage shank depth settings, see “Tillage Shank Depth Adjustment Chart” on page 5-12.

Air Diffuser Installation

The air diffuser can be mounted on either side of the row unit tail. The air diffuser is designed to work with an input hose size of 2 in (5 cm) inside diameter. The output hose size is 1-1/4 in (3.2 cm) inside diameter to match up with the adjustable dry fertilizer boot.

1. Install air diffuser (3), bolts (1), and nuts (2) as shown in Figure 4-10.
2. Tighten bolts to proper torque. See “Torque Specifications” on page 7-2.

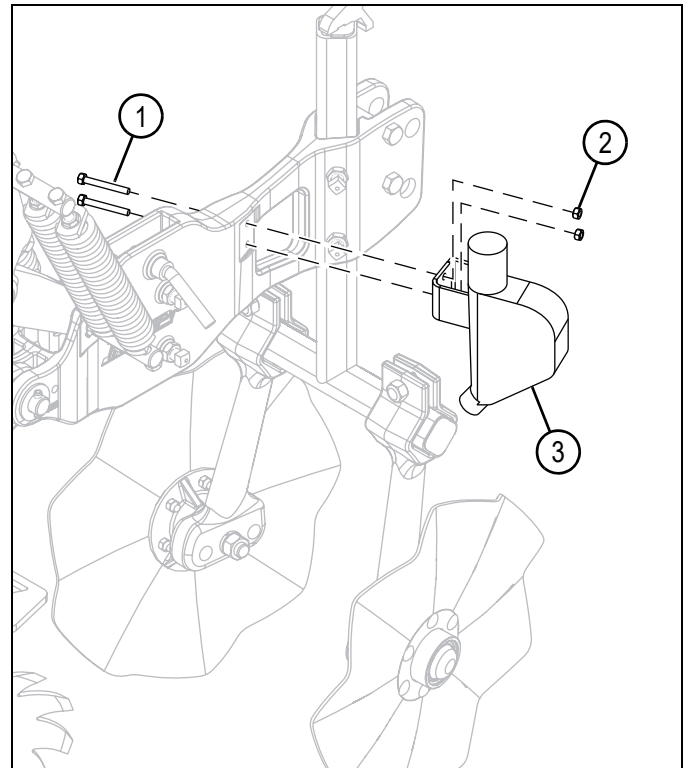

Figure 4-10

ORM000283

- | | |
|------------------|-----------------|
| 1) Bolt (2 used) | 3) Air diffuser |
| 2) Nut (2 used) | |

Tillage Shank Installation

Tools

- 15/16 in Wrench
- 5/8 in Eight-point socket

NOTE: The liquid fertilizer mole shank assembly installation procedure is shown. The shallow tillage assembly, mole shank assembly, and dry mole shank assembly installation procedures are similar.

⚠ DANGER

Avoid crushing. Failure to follow this information will result in death or serious injury. Make sure all personnel are clear of the implement before lowering.

⚠ DANGER

Avoid crushing. An uneven surface could cause the implement to shift or fall, resulting in injury or death as well as implement damage. Park the implement on a clean, dry, level surface.

⚠ DANGER

Avoid crushing. Failure to follow this information will result in death or serious injury. Use bar stands and cylinder stops to support the implement.

1. Lower the implement to support blocks to attain proper height for shank installation.
2. Place the tractor in park, turn off the engine, and remove the key.
3. Remove buildup of grease, oil, and debris prior to installing tillage shank. See "Implement Inspection" on page 7-4.

⚠ CAUTION

Be extremely careful working around unshielded sharp edges. Injury may result from contact with sharp edges.

4. Loosen jam nuts (2) and set bolts (3) to provide adequate shank housing clearance for the shank to be inserted in the bottom side of the tail.

NOTE: Tail tapped holes are cast to both sides of the tail. Jam nuts and set bolts can be moved to the opposite side for ease of adjustment.

5. Remove hair pin (1) and pin (4).

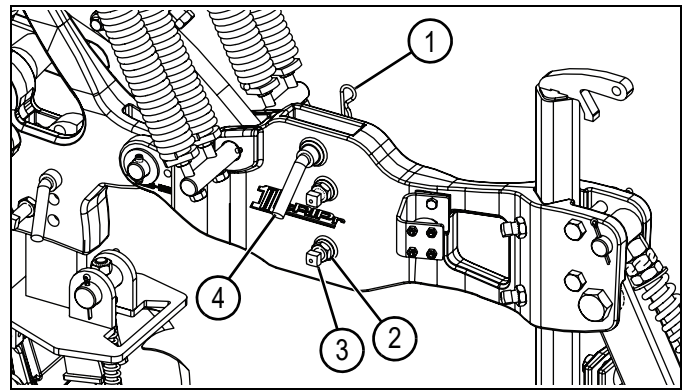

Figure 4-11

ORM000276

- 1) Hair pin
- 2) Jam nut (2 used)
- 3) Set bolt (2 used)
- 4) Pin
- 5) Roll pin
- 6) Remove roll pin (5).
7. Insert tillage shank (6) into shank housing.
8. Insert pin (4) to set desired shank height.
9. Insert hair pin (1) and roll pin (5).

NOTE: Roll pin (5) should not be removed after initial installation.

10. Tighten set bolts (3) and jam nuts (2) to proper torque. See "Torque Specifications" on page 7-2.

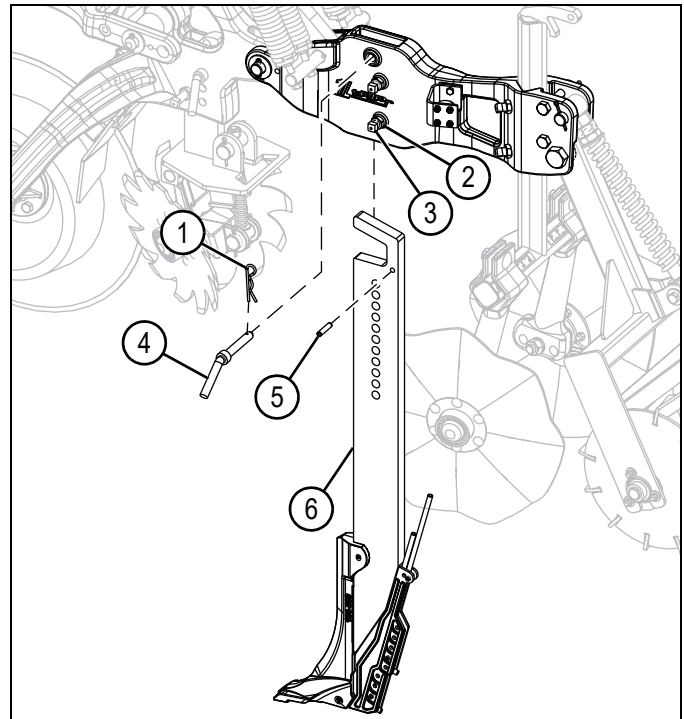

Figure 4-12

ORM000277

- 1) Hair pin
- 2) Jam nut (2 used)
- 3) Set bolt (2 used)
- 4) Pin
- 5) Roll pin
- 6) Tillage shank

For tillage shank depth settings, see "Tillage Shank Depth Adjustment Chart" on page 5-12.

Mole Shank Assembly Fertilizer Tube Installation

⚠ DANGER

Avoid direct exposure to anhydrous ammonia (NH₃) and liquid fertilizer. Failure to follow this information will result in death or serious injury.

If NH₃ or liquid fertilizer is used, it is advisable to consult documented information regarding safe handling and application of NH₃ or liquid fertilizer. Refer to recognized sources. See “Anhydrous Ammonia (NH₃) and Liquid Fertilizer” on page 2-9.

⚠ DANGER

Avoid crushing. Failure to follow this information will result in death or serious injury. Make sure all personnel are clear of the implement before lowering.

⚠ DANGER

Avoid crushing. An uneven surface could cause the implement to shift or fall, resulting in injury or death as well as implement damage. Park the implement on a clean, dry, level surface.

⚠ DANGER

Avoid crushing. Failure to follow this information will result in death or serious injury. Use bar stands and cylinder stops to support the implement.

1. Lower the implement to support blocks to attain proper height for fertilizer tube installation.
2. Place the tractor in park, turn off the engine, and remove the key.
3. Remove buildup of grease, oil, and debris prior to installing fertilizer tubes. See “Implement Inspection” on page 7-4.

⚠ CAUTION

Be extremely careful working around unshielded sharp edges. Injury may result from contact with sharp edges.

4. Distinguish roll pin holes (4) for desired fertilizer placement depth.
5. Insert fertilizer tube (1) between side plates (3).
6. Align desired roll pin holes and fertilizer tube mount tab (5).
7. Insert roll pin (2) through side plate roll pin holes and fertilizer tube mount tab (5).

NOTE: The uppermost roll pin holes and upper roll pin may be used to support the upper portion of the fertilizer tube.

8. Repeat steps 5–8 for second fertilizer tube.

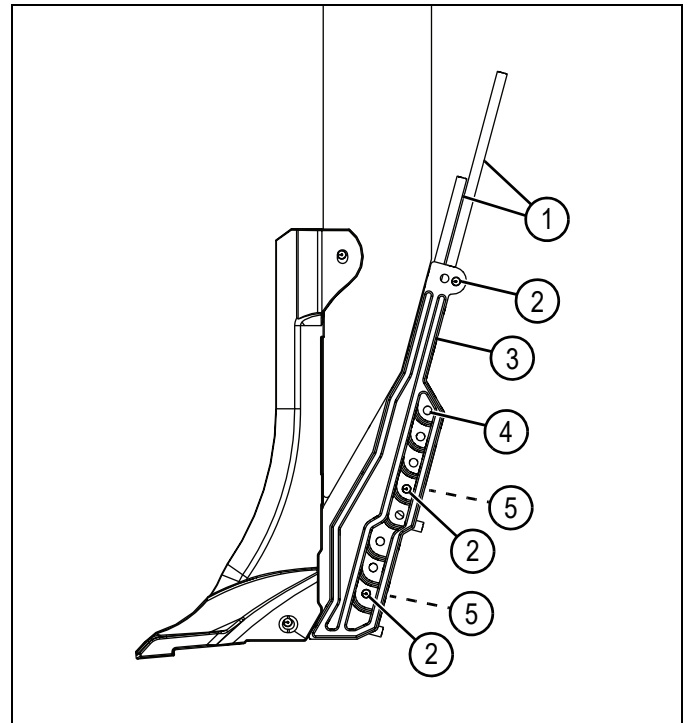

Figure 4-13

ORM000278

- | | |
|-----------------------------|----------------------------|
| 1) Fertilizer tube (2 used) | 4) Roll pin hole (10 used) |
| 2) Roll pin (3 used) | 5) Mount tab (2 used) |
| 3) Side plate (2 used) | |

Mole Knife Assembly Fertilizer Tube Installation

DANGER

Avoid direct exposure to anhydrous ammonia (NH₃) and liquid fertilizer. Failure to follow this information will result in death or serious injury.

If NH₃ or liquid fertilizer is used, it is advisable to consult documented information regarding safe handling and application of NH₃ or liquid fertilizer. Refer to recognized sources. See “Anhydrous Ammonia (NH₃) and Liquid Fertilizer” on page 2-9.

DANGER

Avoid crushing. Failure to follow this information will result in death or serious injury. Make sure all personnel are clear of the implement before lowering.

DANGER

Avoid crushing. An uneven surface could cause the implement to shift or fall, resulting in injury or death as well as implement damage. Park the implement on a clean, dry, level surface.

DANGER

Avoid crushing. Failure to follow this information will result in death or serious injury. Use bar stands and cylinder stops to support the implement.

1. Lower the implement to support blocks to attain proper height for fertilizer tube installation.
2. Place the tractor in park, turn off the engine, and remove the key.
3. Remove buildup of grease, oil, and debris prior to installing fertilizer tubes. See “Implement Inspection” on page 7-4.

CAUTION

Be extremely careful working around unshielded sharp edges. Injury may result from contact with sharp edges.

4. Distinguish roll pin holes (3) for desired fertilizer placement depth.
5. Insert fertilizer tube (1) between side plates (2).
6. Align desired roll pin holes and fertilizer tube mount tab (5).
7. Insert roll pin (4) through side plate roll pin holes and fertilizer tube mount tab (5).

NOTE: The uppermost roll pin holes and upper roll pin may be used to support the upper portion of the fertilizer tube.

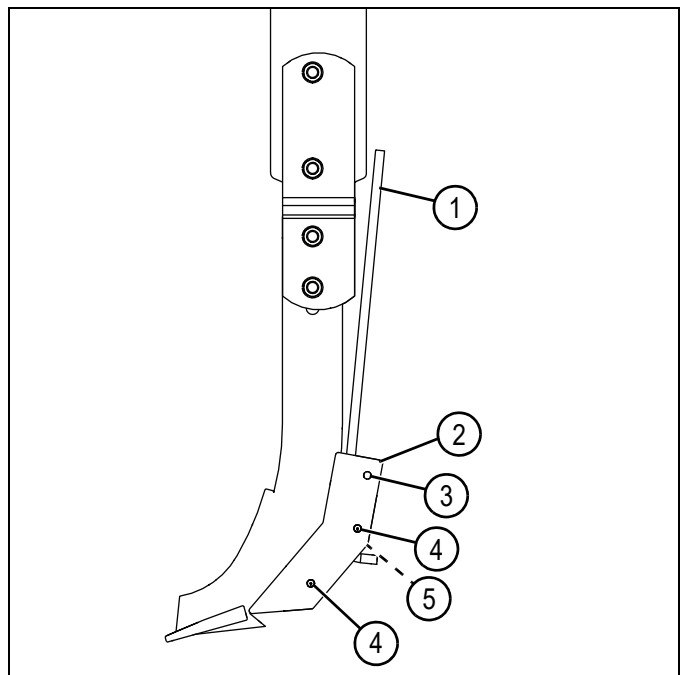

Figure 4-14

ORM000301

- | | |
|---------------------------|----------------------|
| 1) Fertilizer tube | 4) Roll pin (2 used) |
| 2) Side plate (2 used) | 5) Mount tab |
| 3) Roll pin hole (3 used) | |

Dry Mole Shank Assembly Fertilizer Tube and Dry Boot Installation

⚠ DANGER

Avoid direct exposure to anhydrous ammonia (NH₃) and liquid fertilizer. Failure to follow this information will result in death or serious injury.

If NH₃ or liquid fertilizer is used, it is advisable to consult documented information regarding safe handling and application of NH₃ or liquid fertilizer. Refer to recognized sources. See “Anhydrous Ammonia (NH₃) and Liquid Fertilizer” on page 2-9.

⚠ DANGER

Avoid crushing. Failure to follow this information will result in death or serious injury. Make sure all personnel are clear of the implement before lowering.

⚠ DANGER

Avoid crushing. An uneven surface could cause the implement to shift or fall, resulting in injury or death as well as implement damage. Park the implement on a clean, dry, level surface.

⚠ DANGER

Avoid crushing. Failure to follow this information will result in death or serious injury. Use bar stands and cylinder stops to support the implement.

1. Lower the implement to support blocks to attain proper height for fertilizer tube and dry fertilizer boot installation.
2. Place the tractor in park, turn off the engine, and remove the key.
3. Remove buildup of grease, oil, and debris prior to installing fertilizer tube and dry fertilizer boot. See “Implement Inspection” on page 7-4.

⚠ CAUTION

Be extremely careful working around unshielded sharp edges. Injury may result from contact with sharp edges.

4. Remove screws (1) and side plate (2) to access roll pin holes.

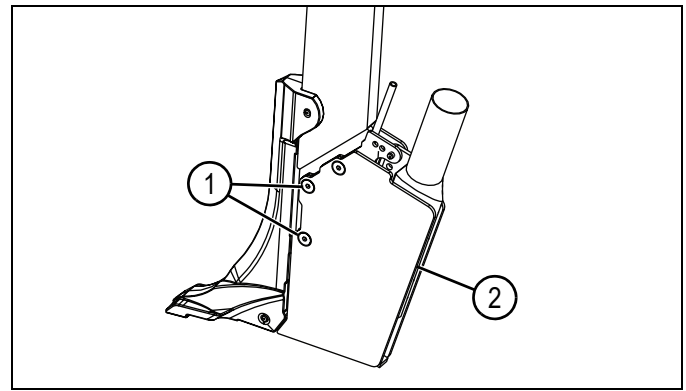

Figure 4-15

ORM000274

- 1) Screw (3 used)
- 2) Side plate
5. Distinguish roll pin holes (7) for desired fertilizer placement depth and place fertilizer tube (3).
6. Align desired roll pin holes and fertilizer tube mount tab (8).
7. Insert roll pin (6) through side plate roll pin holes and fertilizer tube mount tab.
8. Distinguish roll pin holes (7) for desired fertilizer placement depth and place dry fertilizer boot (5).
9. Align desired roll pin holes and dry fertilizer boot mount tabs (4).
10. Insert roll pin (6) through side plate roll pin holes and dry fertilizer boot mount tab.

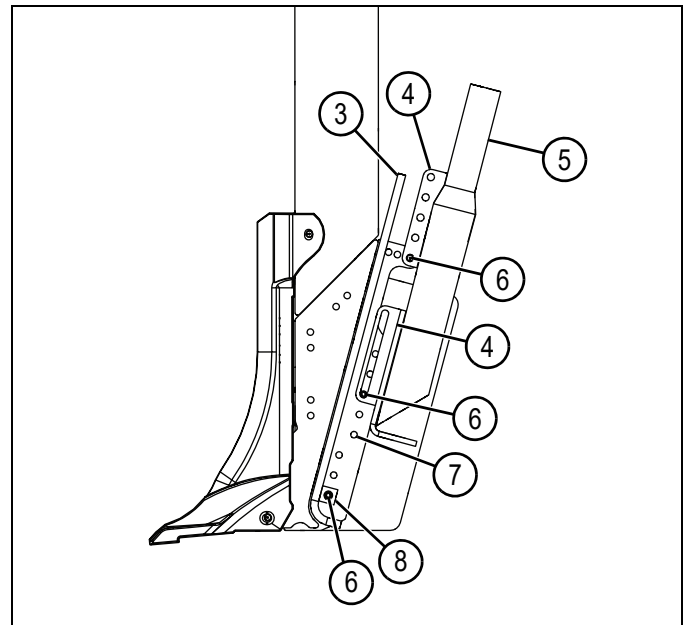

Figure 4-16: (parts removed for clarity)

ORM000279

- 3) Fertilizer tube
- 4) Mount tab (2 used)
- 5) Fertilizer boot
- 6) Roll pin (3 used)
- 7) Roll pin hole (11 used)
- 8) Mount tab

11. Install side plate and screws, see Figure 4-15.

Mole Shank Shin Cap Installation

⚠ DANGER

Avoid crushing. Failure to follow this information will result in death or serious injury. Make sure all personnel are clear of the implement before lowering.

⚠ DANGER

Avoid crushing. An uneven surface could cause the implement to shift or fall, resulting in injury or death as well as implement damage. Park the implement on a clean, dry, level surface.

⚠ DANGER

Avoid crushing. Failure to follow this information will result in death or serious injury. Use bar stands and cylinder stops to support the implement.

1. Lower the implement to the ground, place the tractor in park, turn off the engine, and remove the key.
2. Remove buildup of grease, oil, and debris prior to installing shin caps. See "Implement Inspection" on page 7-4.

⚠ CAUTION

- Be extremely careful working around unshielded sharp edges. Injury may result from contact with sharp edges.
 - Avoid implement damage. Do not strike foot piece ear (8) with hammer.
3. Remove upper roll pin (1) from foot piece (2).

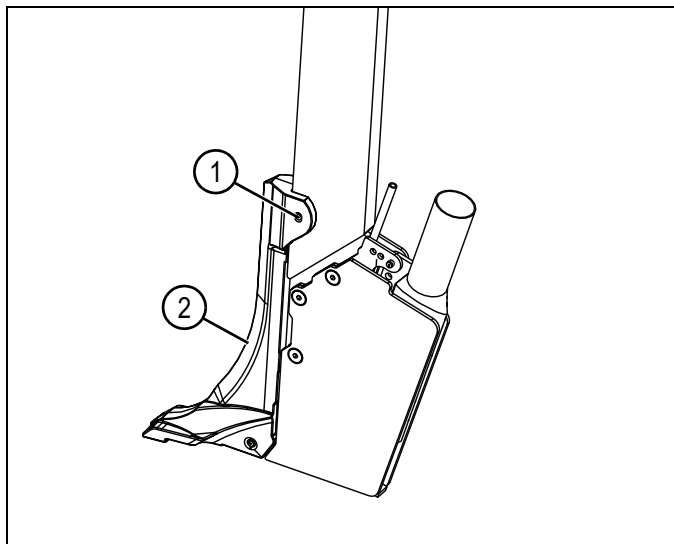

Figure 4-17

ORM000281

- 1) Roll pin
- 2) Foot piece

4. Fit shin cap (5) over foot piece ear (8) and align holes.
5. Using washers (4) on each side, insert bolt (3) through shin cap, foot piece (2), and shank (7).

⚠ CAUTION

Avoid implement damage. Do not over-tighten nut (6) and bolt to avoid damage to the shin cap and foot piece ear.

6. Tighten nut and bolt.

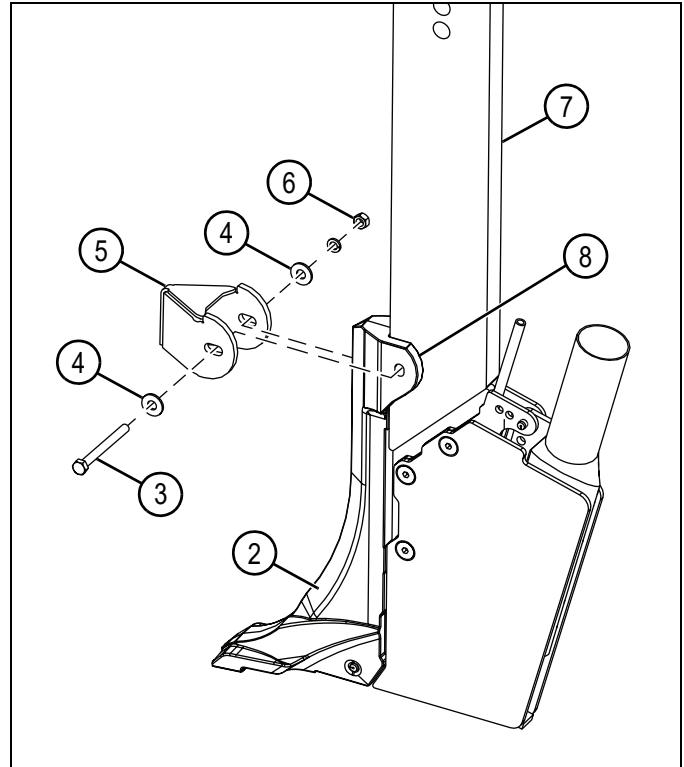

Figure 4-18

ORM000282

- | | |
|--------------------|-------------------|
| 2) Foot piece | 6) Nut |
| 3) Bolt | 7) Shank |
| 4) Washer (2 used) | 8) Foot piece ear |
| 5) Shin cap | |

Automatic Reset (AR) Trip Linkage Installation

One of the most innovative Orthman 1tRIPr® II Row Unit accessories is the automatic reset (AR) trip linkage. This allows the row unit to be tripped by underground obstructions and then automatically reset. This feature helps protect the shank and wavy coulter tooling. The AR trip linkage will be installed on your 1tRIPr® II machine from the factory if ordered with that option.

⚠ DANGER

Avoid crushing. Failure to follow this information will result in death or serious injury. Make sure all personnel are clear of the implement before lowering.

⚠ DANGER

Avoid crushing. An uneven surface could cause the implement to shift or fall, resulting in injury or death as well as implement damage. Park the implement on a clean, dry, level surface.

⚠ DANGER

Avoid crushing. Failure to follow this information will result in death or serious injury. Use bar stands and cylinder stops to support the implement.

1. Lower the implement to the ground, place the tractor in park, turn off the engine, and remove the key.
2. Remove buildup of grease, oil, and debris prior to installing row unit mounts. See “Implement Inspection” on page 7-4.

NOTES:

- It may be easier to manipulate the tail section of the row unit with the tillage shank in a raised position.
- It may be desirable to have the 1tRIPr® II machine lifted up with a tractor so there is no pressure on the tail section of the row units.
- If machine is not hooked to a tractor, it is important to only remove one row unit at a time. Fully complete the installation of one AR linkage before starting on the next row unit, as the tail sections of the row units keep the machine from tipping over backwards.

⚠ DANGER

Avoid crushing. Failure to follow this information will result in death or serious injury. Use an appropriate lifting device to support the tail section.

⚠ CAUTION

Avoid injury. Springs are under tension. Adjust spring tension slowly. Verify tension is loose before removing springs. Failure to follow this information will result in serious injury.

3. Loosen spring tension. See “Automatic Reset (AR) Trip Linkage” on page 5-21.
4. Remove bolts (1), jam nuts (2), and left down-pressure spring (3).
5. Remove bolt (5) and pin (4).
6. Remove spring pin (8), pin (7), and shear bolt assembly (6).

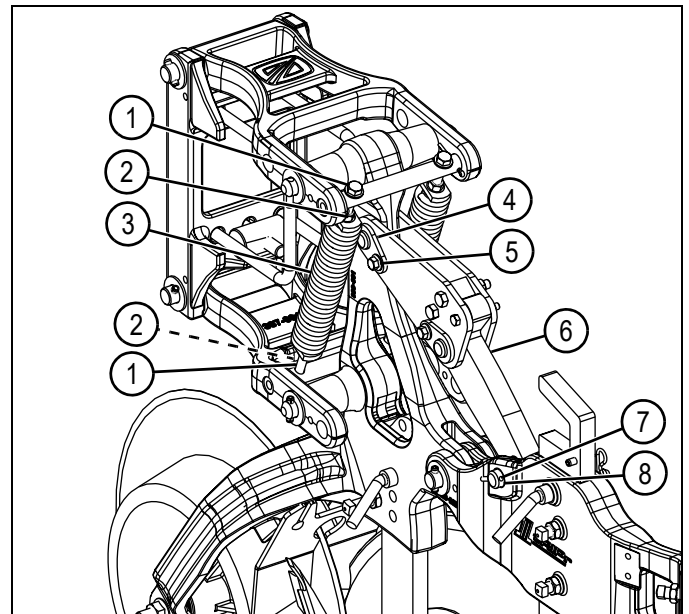

Figure 4-19

ORM000291

- | | |
|---------------------|------------------------|
| 1) Bolt (2 used) | 5) Bolt |
| 2) Jam nut (2 used) | 6) Shear bolt assembly |
| 3) Spring | 7) Pin |
| 4) Pin | 8) Spring pin |

PREPARATION AND SETUP

7. Remove bolt (10) and pin (9) from AR trip linkage package.
8. Remove lower bolts (12), spring pins (11), and pin (13) from AR trip linkage package.

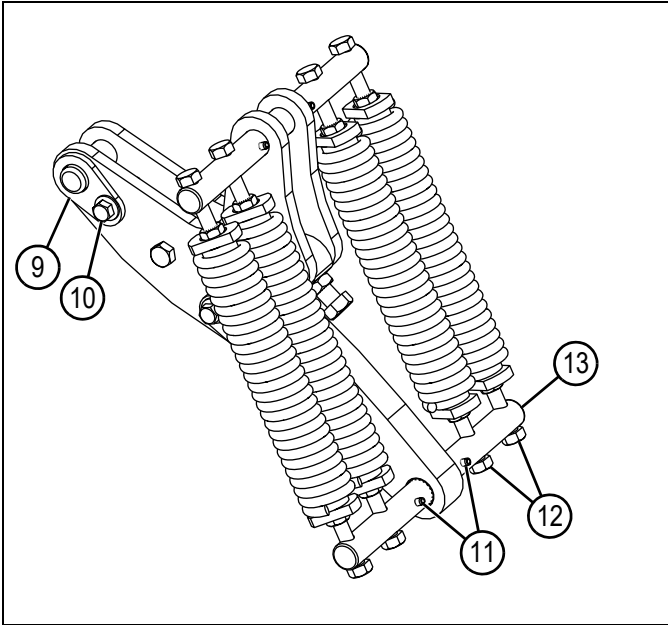

Figure 4-20

ORM000292

- | | |
|-------------------------|-------------------|
| 9) Pin | 12) Bolt (4 used) |
| 10) Bolt | 13) Pin |
| 11) Spring pin (2 used) | |

9. Position the AR trip linkage assembly (14) over the main frame (15) and align pin holes.
10. Insert pin (9) and bolt (10).
11. Lower the AR trip linkage assembly into the tail section (16) and align pin holes.
12. Insert pin (13) and spring pins (11).
13. Align springs and insert bolts (12).

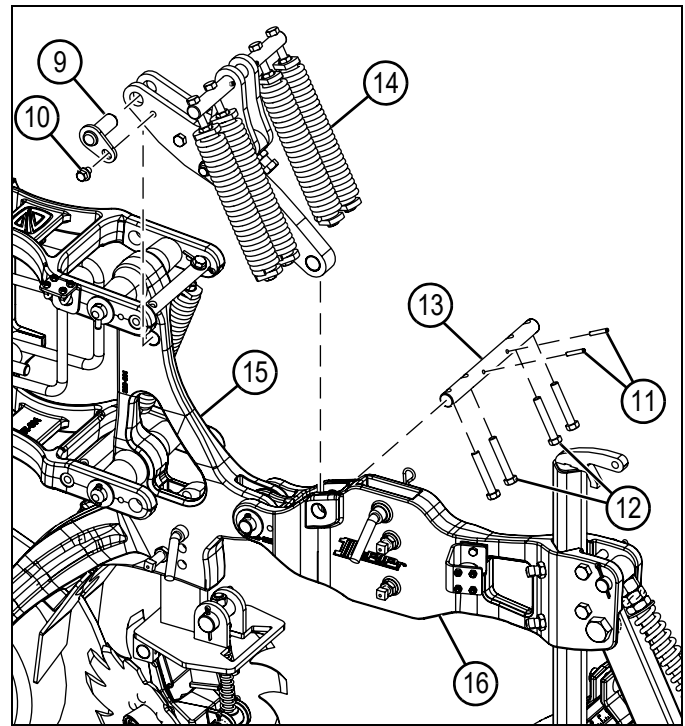

Figure 4-21

ORM000293

- | | |
|-------------------------|------------------------------|
| 9) Pin | 13) Pin |
| 10) Bolt | 14) AR trip linkage assembly |
| 11) Spring pin (2 used) | 15) Main frame |
| 12) Bolt (4 used) | 16) Tail section |

14. Insert bolts (1), jam nuts (2), and left down-pressure spring (3), see Figure 4-19 on page 4-17.

CAUTION

Avoid injury. Springs are under tension. Adjust spring tension slowly. Failure to follow this information will result in serious injury.

15. Tighten spring tension bolts to factory settings. See "Automatic Reset (AR) Trip Linkage" on page 5-21.

Chapter 5

Operation and Field Settings

Toolbar Height and Orientation	5-2
Row Unit Depth	5-2
Field Adjustments	5-4
Row Unit Down Pressure	5-4
Row Unit Down Pressure Adjustment	5-5
Row Cleaner Assembly Depth	5-6
Row Cleaner Assembly Width	5-8
Fore and Aft Adjustment	5-8
Rigid Row Cleaner	5-9
Floating Row Cleaner	5-10
Rolling Basket Down Pressure	5-11
Rolling Basket Down Pressure Adjustment	5-11
Tillage Shank Assembly Depth	5-12
Tillage Shank Assembly Depth Adjustment	5-12
Tillage Shank Depth Adjustment Chart	5-12
Wavy Coulter Assembly Depth and Width	5-14
Wavy Coulter Assembly Depth Adjustment	5-14
Wavy Coulter Assembly Width Adjustment	5-15
Wavy Coulter Assembly Fore and Aft	5-16
Adjustable Liquid Tubes	5-18
Adjustable Dry Fertilizer Boot on Dry Mole Shank	5-19
Shear Bolt Protected Tail	5-20
Automatic Reset (AR) Trip Linkage	5-21

Toolbar Height and Orientation

WARNING

Never allow riders on the tractor or implement. Failure to follow this information could result in death or serious injury.

Riders hinder operator visibility and can be thrown from the implement and/or be struck by foreign objects resulting in injury or death.

1. Connect the implement hitch to the tractor. See “Implement-to-Tractor Connection” on page 4-3.

DANGER

Avoid crushing. Failure to follow this information will result in death or serious injury. Make sure all personnel are clear of the implement before lowering.

2. Lower the implement to the ground, place the tractor in park, turn off the engine, and remove the key.

NOTE: *When setting toolbar height and orientation, disregard row unit performance. Toolbar height and orientation must be established prior to tooling adjustment.*

The top and bottom of the toolbar (3 and 2) must operate parallel with the ground surface. Adjustment of the tractor three-point hitch, lift assist wheels, and/or toolbar gauge wheels (if equipped) will allow the toolbar to operate parallel with the ground surface.

The bottom of the toolbar should operate at an approximate height of 30-32 in (76-81 cm) (1) above the ground surface (4). Use the tractor lower hitch stop, lift assist wheels, and/or toolbar gauge wheels (if equipped) to set desired toolbar height.

Have an assistant pull the tractor and implement slowly forward in the field position as you view the end of the toolbar from a safe distance. Observe toolbar height and orientation while in operation. Make adjustments accordingly until the top and bottom of the toolbar operate parallel with the ground surface and the bottom of the toolbar operates at an approximate height of 30-32 in (76-81 cm) above the ground surface.

For more information, see the toolbar’s operator manual.

After desired toolbar height and orientation is established, set the tractor lower hitch stop, lift assist wheels, and/or toolbar gauge wheels (if equipped).

NOTE: *Larger implements may require lift assist wheels and/or toolbar gauge wheels to support toolbar weight. Lift assist wheels and/or toolbar gauge wheels displace a portion of the toolbar weight to allow maximum parallel linkage travel.*

NOTE: *Smaller implements may operate without lift assist wheels and/or toolbar gauge wheels (if equipped). The tractor hitch will bear a portion of the toolbar weight by setting a lower hitch stop on the tractor three-point hitch control.*

Row Unit Depth

The depth band coulters should allow the toolbar to operate at the desired height and provide consistent row unit tooling depth by governing soil penetration.

Adjustable down pressure springs supply row unit down pressure to assist with row unit soil penetration. Parallel linkages, with the ability to travel vertically, allow row units to operate independent of the toolbar. The depth band, down pressure springs, and parallel linkages should allow the toolbar to serve as a towing device, allowing uniform tillage despite terrain variations. See “Field Adjustments” on page 5-4.

For the toolbar to serve as a towing device, the ground surface, toolbar, and linkage must generally operate parallel to one another when in the field position. See Figure 5-1 on page 5-3. In most field conditions, the linkage will operate at a slight downward angle. See Figure 5-2 on page 5-3.

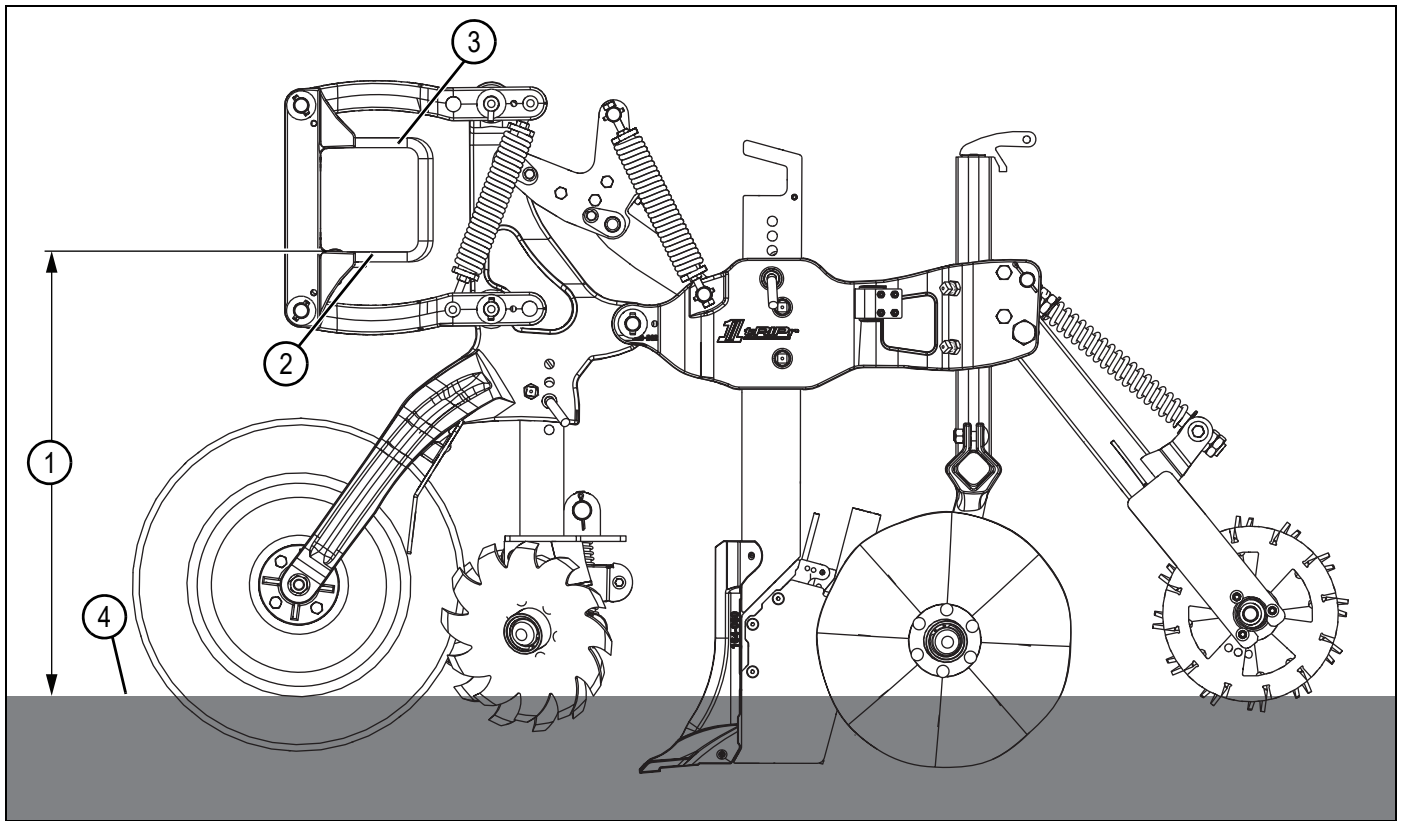

Figure 5-1: Parallel Linkage

ORM000260

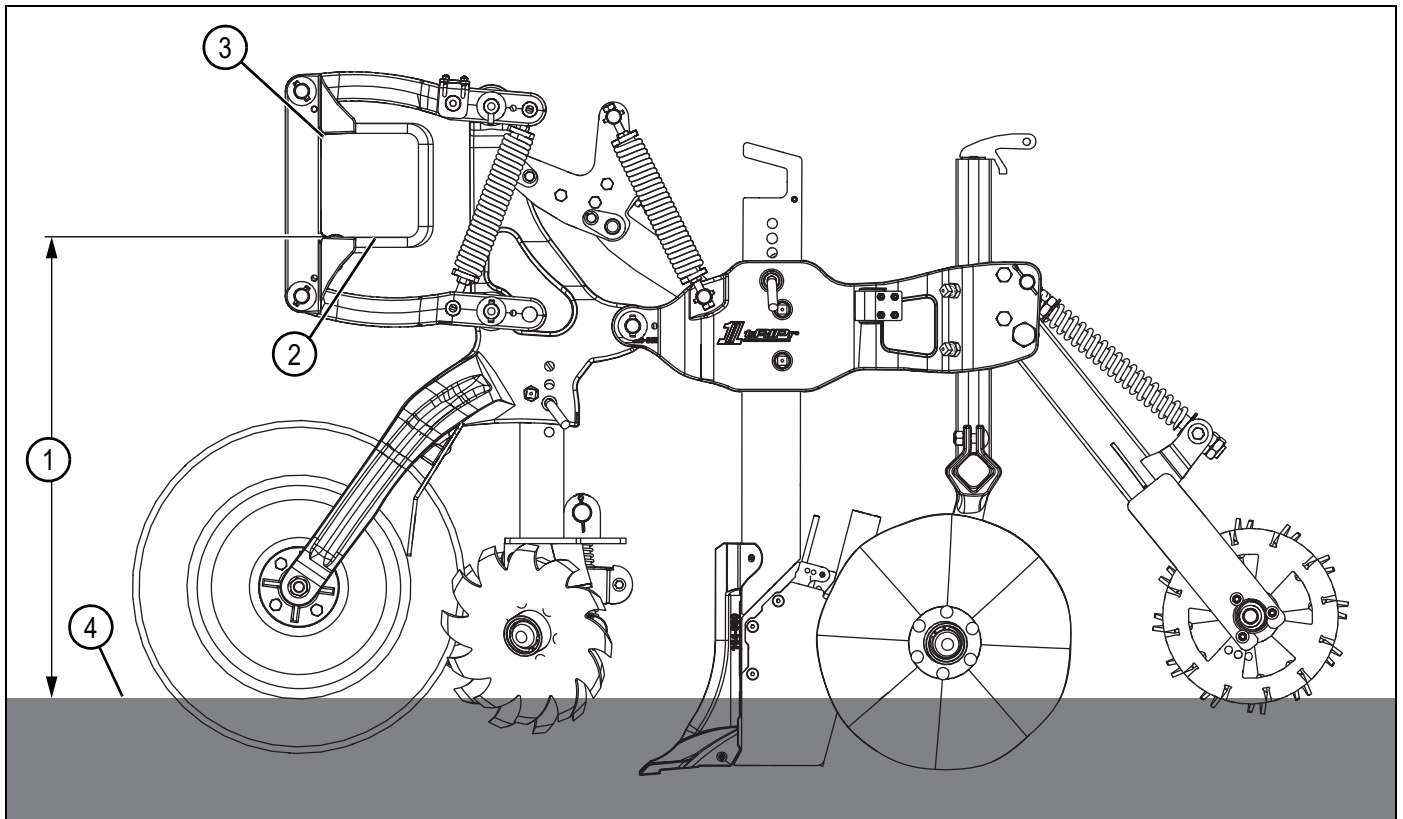

Figure 5-2: Angled Linkage

ORM000261

- 1) Approximate height of 30–32 in (76–81 cm) 2) Bottom of toolbar 3) Top of toolbar 4) Ground surface

Field Adjustments

1. Park implement on a clean, level surface; strong enough to support the weight of the machine.

DANGER

Avoid crushing. Failure to follow this information will result in death or serious injury. Do not stand between the tractor and implement when connecting or disconnecting the implement.

2. Place tractor in park and remove key before dismounting tractor to adjust implement.
3. Before adjusting the implement, remove buildup of grease, oil, and debris. See “Implement Inspection” on page 7-4.
4. Make the following adjustments as necessary:
 - Adjust row unit down pressure. See “Row Unit Down Pressure” on page 5-4.
 - Adjust row cleaner assembly depth. See “Row Cleaner Assembly Depth” on page 5-6.
 - Adjust row cleaner assembly width. See “Row Cleaner Assembly Width” on page 5-8.
 - Adjust tillage shank assembly depth. See “Tillage Shank Assembly Depth” on page 5-12.
 - Adjust wavy coulter assembly depth and width. See “Wavy Coulter Assembly Depth and Width” on page 5-14.
 - Adjust wavy coulter assembly fore and aft. See “Wavy Coulter Assembly Fore and Aft” on page 5-16.
 - Adjust rolling basket down pressure. See “Rolling Basket Down Pressure” on page 5-11.
 - Adjust automatic reset (AR) linkage. See “Automatic Reset (AR) Trip Linkage” on page 5-21.

Row Unit Down Pressure

Two adjustable down pressure springs (4) supply row unit down pressure to assist with row unit tooling soil penetration. After toolbar height and orientation is set, row unit down pressure can be adjusted. See “Toolbar Height and Orientation” on page 5-2.

Down pressure springs should be adjusted so that parallel linkages operate independent of the toolbar and the toolbar serves as a towing device. Compacted soil conditions may require an increase in down pressure and softer soil conditions may require a decrease in down pressure to provide adequate soil penetration across the implement.

If a rigid toolbar is used with the 1tRIPr® II Row Units, down pressure adjustment between row units will typically vary slightly.

If a folding toolbar is used, wing sections tend to float upward unless mechanically restrained. Wing row units that are not mechanically restrained may require a decreased amount of down pressure to allow row units to perform consistently across the implement.

For more information, see the toolbar operator’s manual.

Row Unit Down Pressure Adjustment

Tools
<ul style="list-style-type: none"> • 3/4 in Wrench
<ul style="list-style-type: none"> • 1-1/4 in Wrench

⚠ DANGER

Avoid crushing. Failure to follow this information will result in death or serious injury. Make sure all personnel are clear of the implement before lowering.

⚠ DANGER

Avoid crushing. An uneven surface could cause the implement to shift or fall, resulting in injury or death as well as implement damage. Park the implement on a clean, dry, level surface.

⚠ DANGER

Avoid crushing. Failure to follow this information will result in death or serious injury. Use bar stands and cylinder stops to support the implement.

1. Lower the implement to the ground, place the tractor in park, turn off the engine, and remove the key.
2. Remove buildup of grease, oil, and debris prior to adjusting row unit down pressure. See "Implement Inspection" on page 7-4.

⚠ CAUTION

Be extremely careful working around unshielded sharp edges. Injury may result from contact with sharp edges.

3. Loosen the jam nuts (2) from the spring plugs (3).
4. Adjust the down pressure adjustment bolts (1).

NOTE: Adjust both down pressure springs (4) evenly. Turn clockwise (CW) to increase the spring tension, creating more row unit down pressure. Turn counterclockwise (CCW) to decrease the spring tension, reducing the row unit down pressure.

5. Tighten jam nut against spring plug and torque to specification. See "Torque Specifications" on page 7-2.

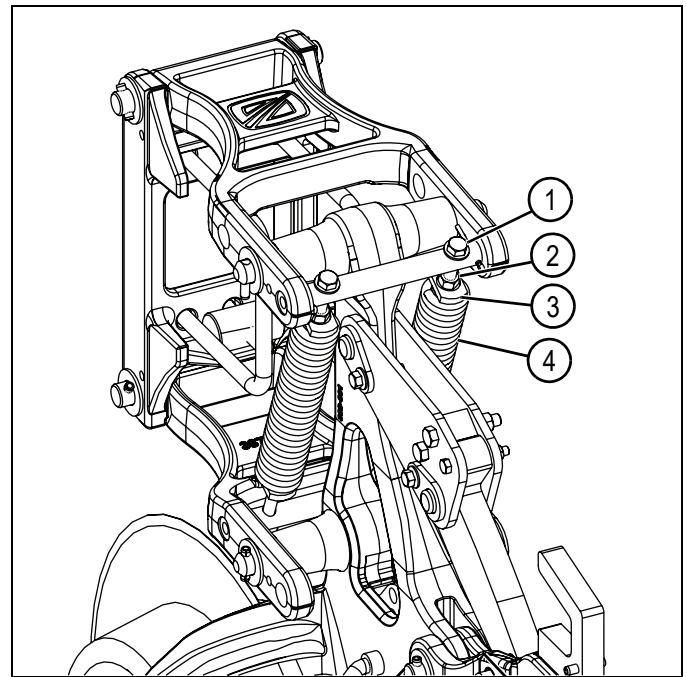

Figure 5-3

ORM000259

- | | |
|---|----------------------------------|
| 1) Down pressure adjustment bolt (2 used) | 3) Spring plug (4 used) |
| 2) Jam nut (2 used) | 4) Down pressure spring (2 used) |

NOTE: Too much down pressure applied to the individual row units can essentially lift the toolbar to an undesirable operating height. Lifting the toolbar will cause the parallel linkages to "bottom out" and the row units will not operate independent of the toolbar, resulting in non-uniform tillage across the implement.

Row Cleaner Assembly Depth

NOTE: The floating row cleaner assembly is shown. The rigid row cleaner assembly is similar.

The row cleaner assembly reduces field residue directly behind the depth band coulter assembly prior to the arrival of rearward tooling. The row cleaner assembly can be adjusted vertically in 1/4 in (0.64 cm) increments.

DANGER

Avoid crushing. Failure to follow this information will result in death or serious injury. Make sure all personnel are clear of the implement before lowering.

DANGER

Avoid crushing. An uneven surface could cause the implement to shift or fall, resulting in injury or death as well as implement damage. Park the implement on a clean, dry, level surface.

DANGER

Avoid crushing. Failure to follow this information will result in death or serious injury. Use bar stands and cylinder stops to support the implement.

1. Lower the implement to the ground, place the tractor in park, turn off the engine, and remove the key.
2. Remove buildup of grease, oil, and debris prior to adjusting row cleaner assembly depth. See "Implement Inspection" on page 7-4.

CAUTION

Be extremely careful working around unshielded sharp edges. Injury may result from contact with sharp edges.

NOTE: To gently remove surface residue with minimal soil disturbance, the recommended row cleaner assembly depth is approximately 1/2 in (1.27 cm) below soil surface. Row cleaner assemblies are often removed when operating in a low residue cover crop such as drilled wheat, alfalfa, and beans.

3. Support row cleaner assembly (5).
4. Loosen jam nut (3) and set bolt (4).
5. Remove hairpin (2) and depth adjustment pin (1).

NOTE: The floating row cleaner provides 1.75 in (4.4 cm) of travel to allow constant contact with the ground. The bolt within the spring should be tightened so the spring does not slide on the bolt but avoids compression of the spring.

6. Adjust row cleaner assembly to desired depth.
7. Install depth adjustment pin and hairpin.
8. Tighten the jam nut and set bolt and torque to specification. See "Torque Specifications" on page 7-2.

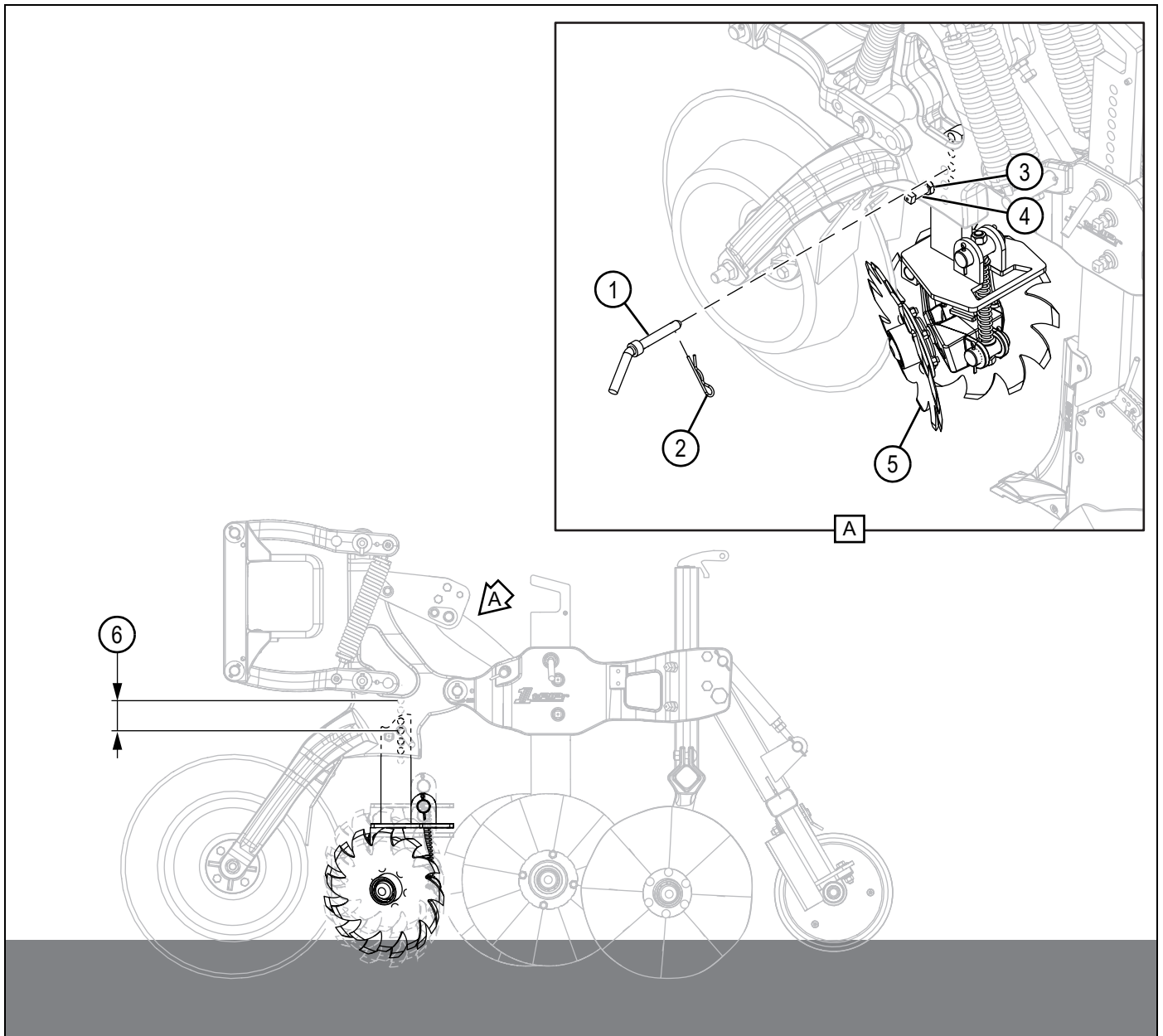

Figure 5-4

ORM000286

- | | | |
|-------------------------|-------------|-------------------------|
| 1) Depth adjustment pin | 3) Jam nut | 5) Row cleaner assembly |
| 2) Hairpin | 4) Set bolt | 6) Depth setting |

Row Cleaner Assembly Width

The row cleaner assembly reduces field residue directly behind the depth band coulter assembly prior to the arrival of rearward tooling. The row cleaner assembly can be adjusted fore and aft.

The row cleaner discs can be adjusted fore and aft by removing them and changing their position to one of three holes on the row cleaner mount. Each rearward hole moves the disc assembly nearly 1 in (2.54 cm) further away from the depth band coulter. As the discs are moved rearward, the distance between the discs will increase.

There are two spacers along with a washer that set the width between the discs. A combination of these spacers may be used to attain different widths between discs at different fore and aft positions. As discs are moved rearward, it is advisable to remove spacers to decrease the width between the discs.

Fore and Aft Adjustment

NOTE: Adjustment for left row cleaner disc is shown.
Adjustment for right row cleaner disc is similar.

Tools
• Snap ring pliers
• 1-1/8 in Wrench

DANGER

Avoid crushing. Failure to follow this information will result in death or serious injury. Make sure all personnel are clear of the implement before lowering.

DANGER

Avoid crushing. An uneven surface could cause the implement to shift or fall, resulting in injury or death as well as implement damage. Park the implement on a clean, dry, level surface.

DANGER

Avoid crushing. Failure to follow this information will result in death or serious injury. Use bar stands and cylinder stops to support the implement.

1. Lower the implement to the ground, place the tractor in park, turn off the engine, and remove the key.

2. Remove buildup of grease, oil, and debris prior to adjusting row cleaner assembly width. See "Implement Inspection" on page 7-4.

CAUTION

Be extremely careful working around unshielded sharp edges. Injury may result from contact with sharp edges.

3. Remove snap ring (1) and cap (2).
4. Remove nut (9), washer (8), bushings (6 and 7), and bolt (4).
5. Adjust the left row cleaner disc (5) to desired position.
6. Install bolt, bushings, washer, and nut.
7. Tighten nut and bolt to specification. See "Torque Specifications" on page 7-2.
8. Inspect O-ring (3) and replace if necessary.
9. Install cap and snap ring.

Rigid Row Cleaner

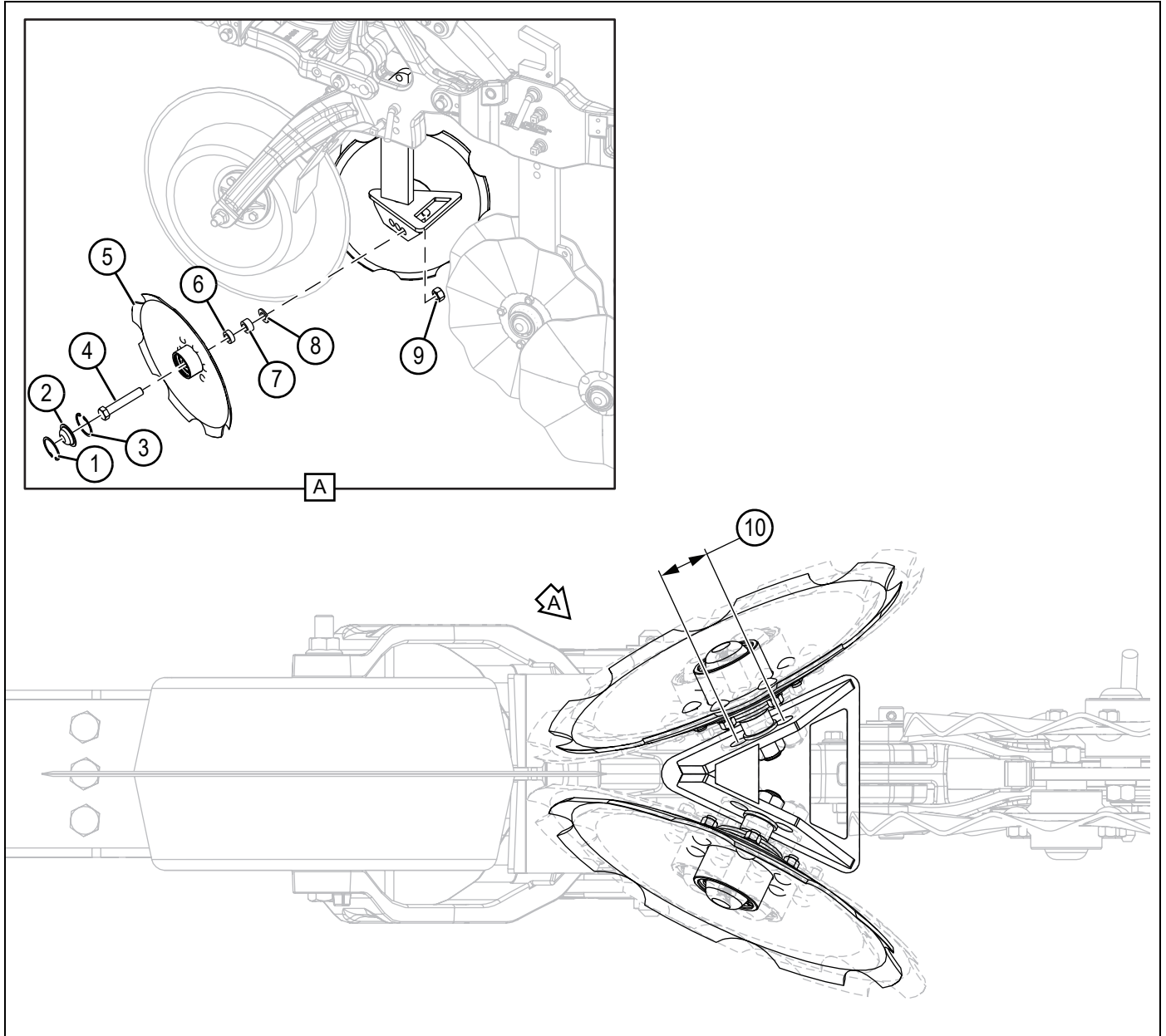

Figure 5-5

ORM000287

- | | | | | |
|--------------|-----------|---------------------|------------|-------------------|
| 1) Snap ring | 3) O-ring | 5) Row cleaner disc | 7) Bushing | 9) Nut |
| 2) Cap | 4) Bolt | 6) Bushing | 8) Washer | 10) Width setting |

Floating Row Cleaner

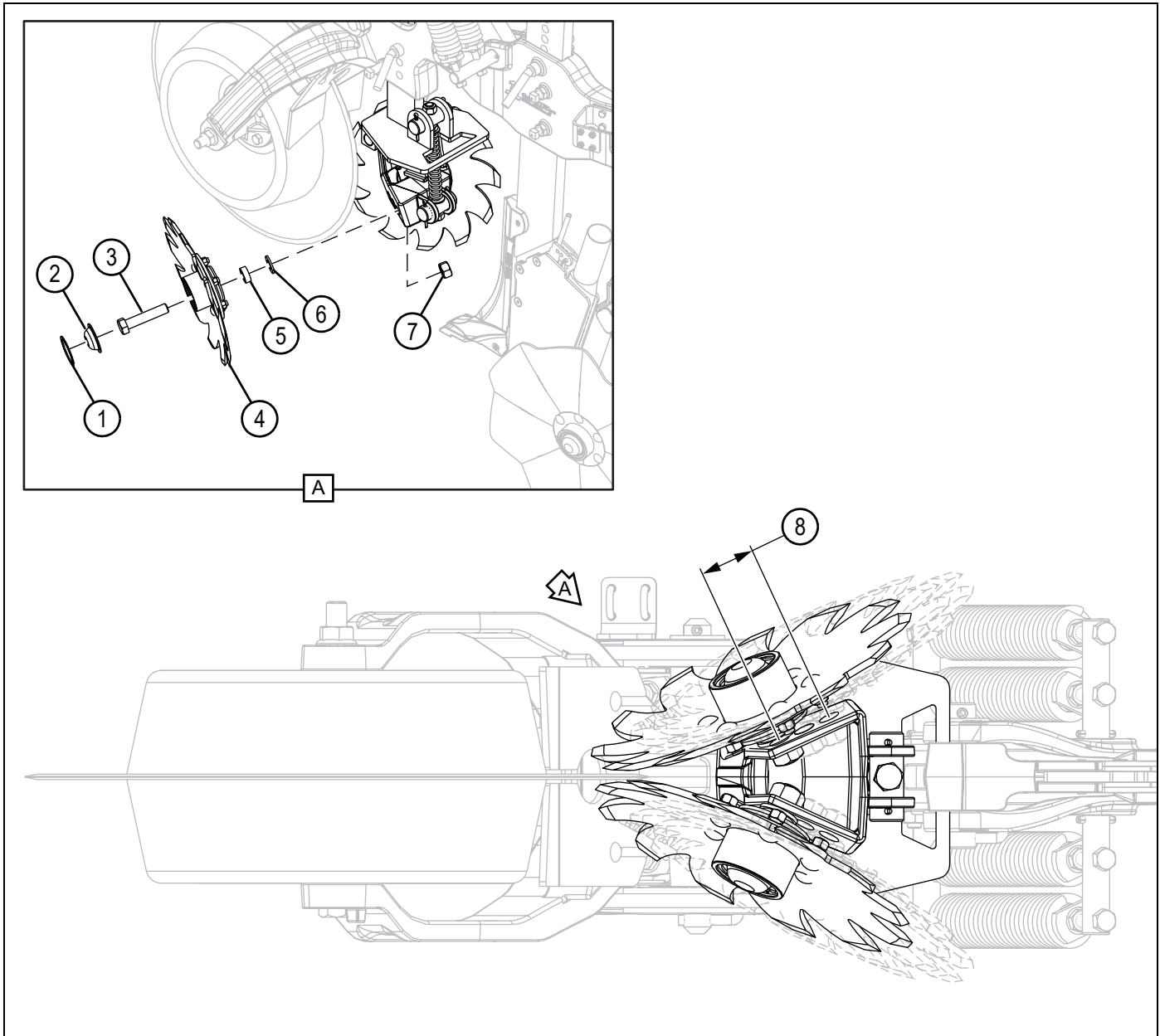

Figure 5-6

ORM000299

- | | | | |
|--------------|---------------------|------------|------------------|
| 1) Snap ring | 3) Bolt | 5) Bushing | 7) Nut |
| 2) Cap | 4) Row cleaner disc | 6) Washer | 8) Width setting |

Rolling Basket Down Pressure

An optional rolling basket assembly is available to complement the 1tRIPr® II Row Unit. Rolling baskets reduce clod size to decrease soil variability, retain existing soil moisture, and complete the optimum seedbed. Rolling baskets are mounted to the rear of the row unit tail section. See “Rolling Basket Assembly Installation” on page 4-8.

Rolling Basket Down Pressure Adjustment

Tools
<ul style="list-style-type: none"> • 3/4 in Wrench
<ul style="list-style-type: none"> • 1-1/2 in Wrench

⚠ DANGER

Avoid crushing. Failure to follow this information will result in death or serious injury. Make sure all personnel are clear of the implement before lowering.

⚠ DANGER

Avoid crushing. An uneven surface could cause the implement to shift or fall, resulting in injury or death as well as implement damage. Park the implement on a clean, dry, level surface.

⚠ DANGER

Avoid crushing. Failure to follow this information will result in death or serious injury. Use bar stands and cylinder stops to support the implement.

1. Lower the implement to the ground, place the tractor in park, turn off the engine, and remove the key.
2. Remove buildup of grease, oil, and debris prior to adjusting rolling basket down pressure. See “Implement Inspection” on page 7-4.

⚠ CAUTION

Be extremely careful working around unshielded sharp edges. Injury may result from contact with sharp edges.

3. Loosen jam nut (2) and adjust tension nut (3) as desired.

NOTE: Tighten tension nut to increase the spring tension, creating more rolling basket (6) down pressure. Loosen tension nut to decrease the spring tension, reducing the rolling basket down pressure.

4. Tighten jam nut and torque to specification. See “Torque Specifications” on page 7-2.

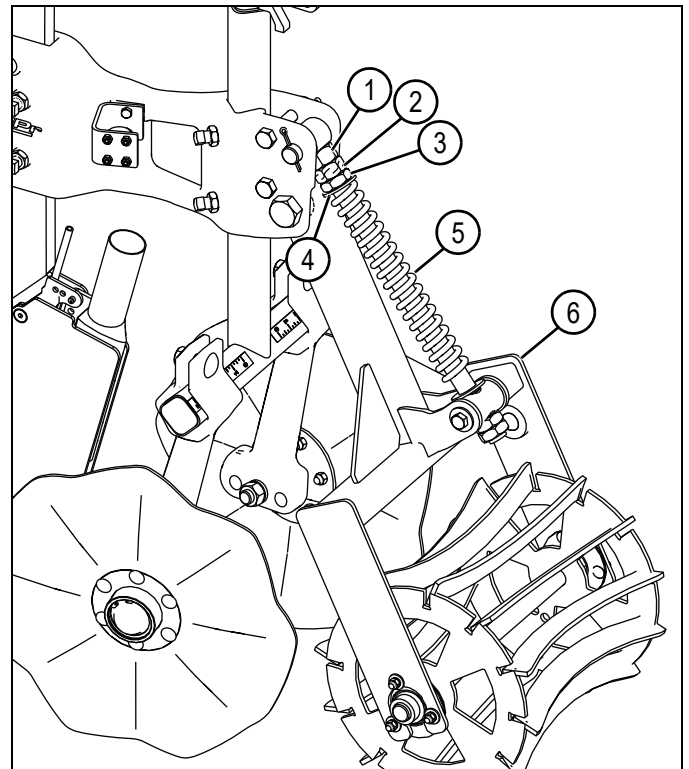

Figure 5-7

ORM00284

- | | |
|----------------|-------------------|
| 1) Hex nut | 4) Washer |
| 2) Jam nut | 5) Spring |
| 3) Tension nut | 6) Rolling basket |

Tillage Shank Assembly Depth

The mole shank assembly shatters the root zone compacted layer while placing fertilizer at two precision depths, if desired. Once the compacted layer depth and thickness is researched and established, the tillage shank assembly depth is adjusted accordingly.

Varying compacted layer depth and thickness, either within or between fields, will warrant tillage shank depth adjustment. The tillage shank point should operate in close proximity to the lowest point of the compacted layer. Operating the tillage shank point below the compacted layer will heave and lift the compacted layer. It is recommended to operate the tillage shank point near, but not past, the lowest point of the compacted layer for optimum performance.

NOTE: *Depth adjustment of the Mole Shank/Dry Mole Shank and wavy coulters should always be done in conjunction with each other.*

Toolbar height and orientation must be established prior to adjusting tillage shank depth. See “Toolbar Height and Orientation” on page 5-2.

Tillage Shank Assembly Depth Adjustment

Figure 5-8 on page 5-13.

Tools
<ul style="list-style-type: none"> • 15/16 in Wrench
<ul style="list-style-type: none"> • 5/8 in Socket

⚠ DANGER

Avoid crushing. Failure to follow this information will result in death or serious injury. Make sure all personnel are clear of the implement before lowering.

⚠ DANGER

Avoid crushing. An uneven surface could cause the implement to shift or fall, resulting in injury or death as well as implement damage. Park the implement on a clean, dry, level surface.

⚠ DANGER

Avoid crushing. Failure to follow this information will result in death or serious injury. Use bar stands and cylinder stops to support the implement.

1. Lower the implement to the ground, place the tractor in park, turn off the engine, and remove the key.

2. Remove buildup of grease, oil, and debris prior to adjusting tillage shank assembly depth. See “Implement Inspection” on page 7-4.

⚠ CAUTION

Be extremely careful working around unshielded sharp edges. Injury may result from contact with sharp edges.

3. Support tillage shank assembly (1).
4. Loosen jam nuts (3) and set bolts (2).
5. Remove hairpin (4) and depth adjustment pin (5).
6. Adjust tillage shank assembly to desired depth setting (6). For depth settings, see “Tillage Shank Depth Adjustment Chart” on page 5-12.
7. Install depth adjustment pin and hairpin.
8. Tighten jam nuts and set bolts to specification. See “Torque Specifications” on page 7-2.

NOTE: *Jam nuts and set bolts can be moved to the opposite side for ease of adjustment. Be sure to remove plug bolts to protect threads.*

Tillage Shank Depth Adjustment Chart

NOTE: *Tillage shank depth setting (6) can be adjusted using the 11 adjustment holes (see Figure 5-8 on page 5-13). The tillage shank adjustment holes are set at 1 in (2.5 cm) increments.*

Setting	Depth
Bottom hole	1 in (2.5 cm)
2nd hole	2 in (5.1 cm)
3rd hole	3 in (7.6 cm)
4th hole	4 in (10.2 cm)
5th hole	5 in (12.7 cm)
6th hole	6 in (15.2 cm)
7th hole	7 in (17.8 cm)
8th hole	8 in (20.3 cm)
9th hole	9 in (22.9 cm)
10th hole	10 in (25.4 cm)
11th hole	11 in (27.9 cm)

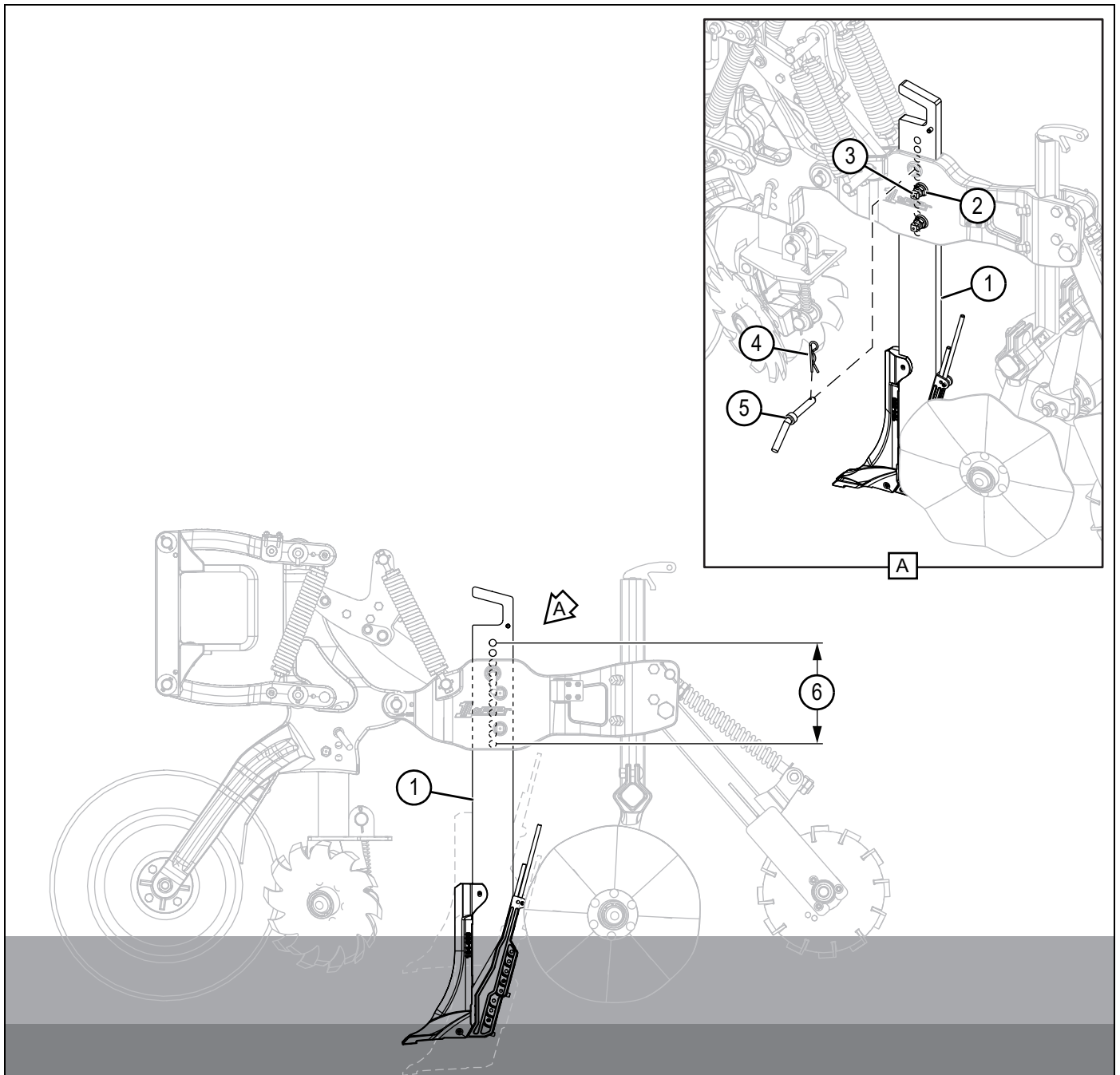

Figure 5-8

ORM000285

- | | | |
|---------------------------|---------------------|-------------------------|
| 1) Tillage shank assembly | 3) Jam nut (2 used) | 5) Depth adjustment pin |
| 2) Set bolt (2 used) | 4) Hairpin | 6) Depth setting |

Wavy Coulter Assembly Depth and Width

Wavy coulter assemblies provide “lift and pinch” action to incorporate field residue, till, and firm the seedbed.

Tools
• 15/16 in Wrench
• 5/8 in Socket

⚠ DANGER

Avoid crushing. Failure to follow this information will result in death or serious injury. Make sure all personnel are clear of the implement before lowering.

⚠ DANGER

Avoid crushing. An uneven surface could cause the implement to shift or fall, resulting in injury or death as well as implement damage. Park the implement on a clean, dry, level surface.

⚠ DANGER

Avoid crushing. Failure to follow this information will result in death or serious injury. Use bar stands and cylinder stops to support the implement.

1. Lower the implement to the ground, place the tractor in park, turn off the engine, and remove the key.
2. Remove buildup of grease, oil, and debris prior to adjusting wavy coulter assembly depth and width. See “Implement Inspection” on page 7-4.

⚠ CAUTION

Be extremely careful working around unshielded sharp edges. Injury may result from contact with sharp edges.

Wavy Coulter Assembly Depth Adjustment

1. Support wavy coulter assembly (1).
2. Loosen jam nuts (3) and set bolts (2).
3. Adjust wavy coulter assembly to desired depth.
4. Tighten jam nuts and set bolts to specification. See “Torque Specifications” on page 7-2.

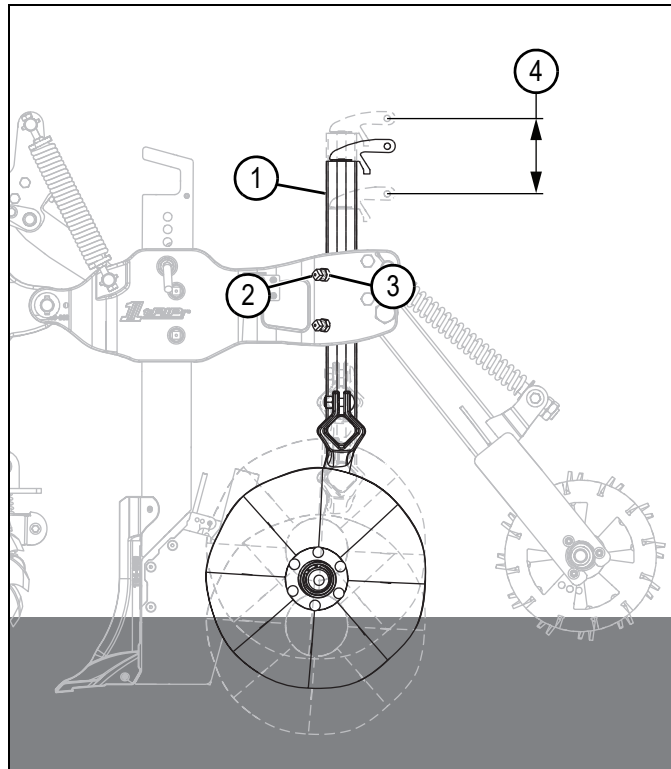

Figure 5-9

ORM000289

- 1) Wavy coulter assembly
- 2) Set bolt (2 used)
- 3) Jam nut (2 used)
- 4) Depth setting

Wavy Coulter Assembly Width Adjustment

1. Loosen nuts (4).
2. Adjust wavy coulter disc assemblies (3) to desired width.
3. Tighten nuts to specification. See "Torque Specifications" on page 7-2.

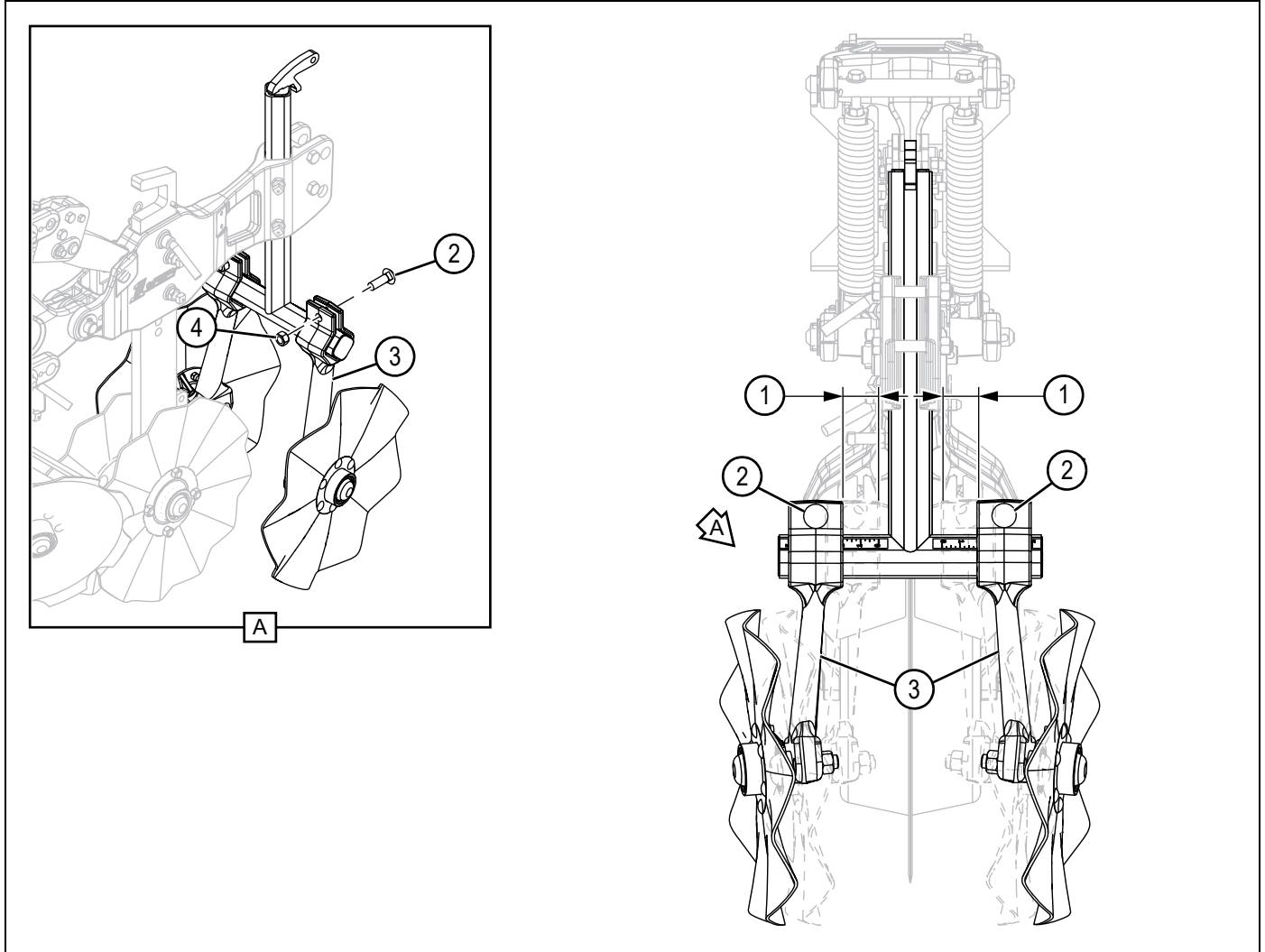

Figure 5-10

ORM000288

- 1) Width setting (2 used) 2) Bolt (2 used) 3) Wavy coulter disc assembly (2 used) 4) Nut (2 used)

Wavy Coulter Assembly Fore and Aft

NOTE: Adjustment for left wavy coulter assembly disc is shown. Adjustment for right wavy coulter assembly disc is similar.

Each wavy coulter assembly can be adjusted fore and aft.

NOTE: If utilizing a Combo Caddy and the 1tRIPr® II Row Units are mounted to a double toolbar, the wavy coulters near the Combo Caddy lift wheels must occupy the forward most shank bolt holes.

Tools
• Snap ring pliers
• 1-1/8 in Wrench

DANGER

Avoid crushing. Failure to follow this information will result in death or serious injury. Make sure all personnel are clear of the implement before lowering.

DANGER

Avoid crushing. An uneven surface could cause the implement to shift or fall, resulting in injury or death as well as implement damage. Park the implement on a clean, dry, level surface.

DANGER

Avoid crushing. Failure to follow this information will result in death or serious injury. Use bar stands and cylinder stops to support the implement.

1. Lower the implement to the ground, place the tractor in park, turn off the engine, and remove the key.

2. Remove buildup of grease, oil, and debris prior to adjusting wavy coulter assembly fore and aft. See "Implement Inspection" on page 7-4.

CAUTION

Be extremely careful working around unshielded sharp edges. Injury may result from contact with sharp edges.

3. Remove snap ring (1) and cap (2).
4. Remove nut (7), lock washer (6), spacer (5), and bolt (3).
5. Adjust left wavy coulter assembly disc (4) to desired position.
6. Install bolt, spacer, lock washer, and nut.
7. Tighten nut and bolt to specification. See "Torque Specifications" on page 7-2.
8. Install cap and snap ring.

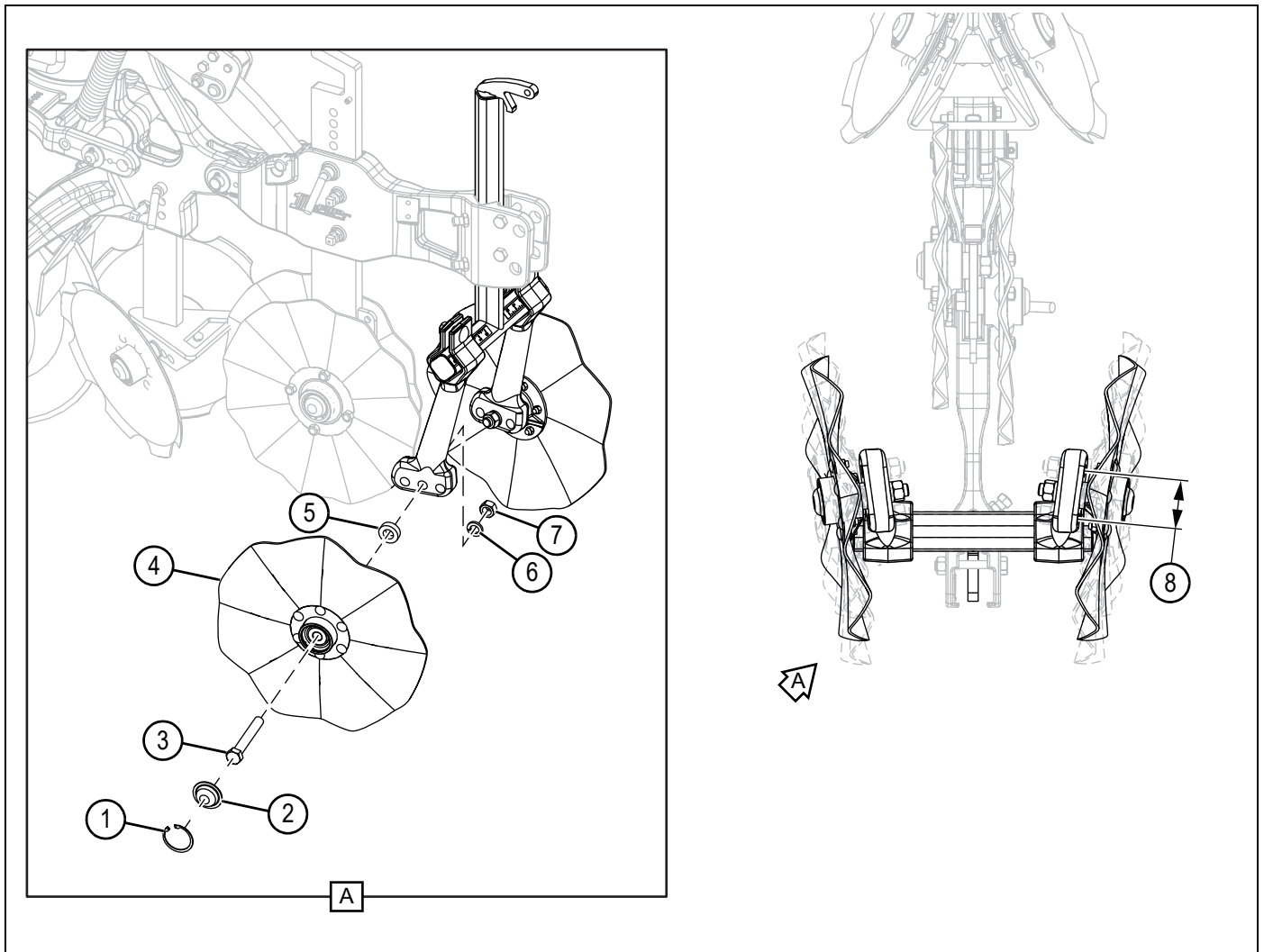

Figure 5-11

ORM000290

- | | | | |
|--------------|------------------------------------|----------------|-------------------------|
| 1) Snap ring | 3) Bolt | 5) Spacer | 7) Nut |
| 2) Cap | 4) Left wavy coulter assembly disc | 6) Lock washer | 8) Fore and aft setting |

Adjustable Liquid Tubes

⚠ DANGER

Avoid direct exposure to anhydrous ammonia (NH₃) and liquid fertilizer. Failure to follow this information will result in death or serious injury.

If NH₃ or liquid fertilizer is used, it is advisable to consult documented information regarding safe handling and application of NH₃ or liquid fertilizer. Refer recognized sources. See “Anhydrous Ammonia (NH₃) and Liquid Fertilizer” on page 2-9.

The Orthman 1tRIPr® II Mole Shank Assembly can be used to place fertilizer at two different depths simultaneously. Depending on the fertilizer setup, it could be used to apply two different rates of fertilizer in the strip at precisely two different depths.

The lowest setting is 1 in (2.54 cm) above the deepest part of the mole point. The holes in the side plate (2) are arranged vertically in 1 in (2.54 cm) increments. This will help you calculate at what depth you are applying fertilizer. For example, if you have the shank set to till at a depth of 9 in (22.86 cm), the fertilizer tubes (8) would be applying fertilizer at depths of 8 in (20.32 cm) and 4 in (10.16 cm). See Figure 5-12.

NOTE: The example shown is just one possible setting. The specific soil conditions, fertilizer placement points, and fertilizer amounts will vary due to each user’s agronomic requirements.

The tube retainer holes (4) are used to retain the liquid fertilizer tube or tubes. Use the innermost hole for retention if you are only utilizing one fertilizer tube, and use the outermost hole for retention if you are utilizing dual fertilizer tubes. For more information on adjustable liquid tubes, see “Mole Shank Assembly Fertilizer Tube Installation” on page 4-13.

The tops of the fertilizer tubes may need to be bent or formed at the top for better fit up to the end user’s fertilizer hose routing and hose clamps. Use caution when forming the fertilizer tubes, as to not kink the tube.

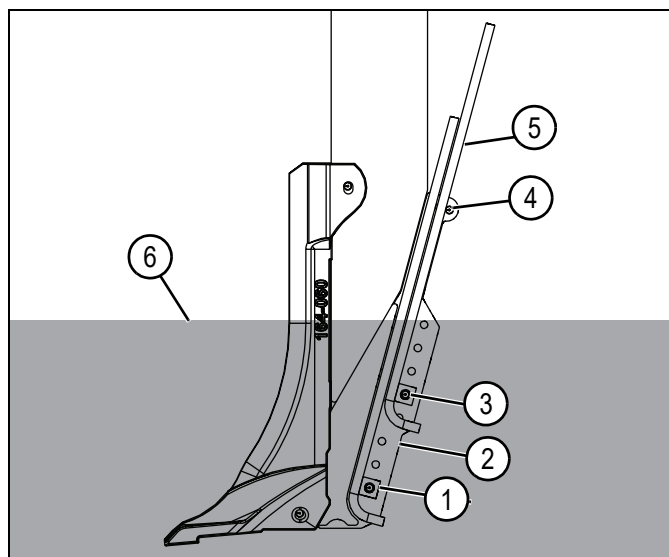

Figure 5-12: Adjustable Liquid Tubes (wear plate removed for clarity)

ORM000265

- | | |
|------------------------------|--------------------------------|
| 1) Fertilizer tube mount tab | 4) Tube retainer hole (2 used) |
| 2) Side plate | 5) Fertilizer tube (2 used) |
| 3) Roll pin (2 used) | 6) Ground surface |

The 1tRIPr® II tail has routing brackets that can be used for liquid or NH₃ fertilizer tube routing. A front routing bracket (7) mounted to the parallel linkage, and a back routing bracket (9) mounted to the tail section allows for the tubing to be held in place.

NOTE: If applying two different types of fertilizer, like NH₃ through one tube and liquid fertilizer through the other tube, it is the responsibility of the user to adequately insulate or add additional space between the tubes to prevent the NH₃ from freezing the liquid fertilizer tube.

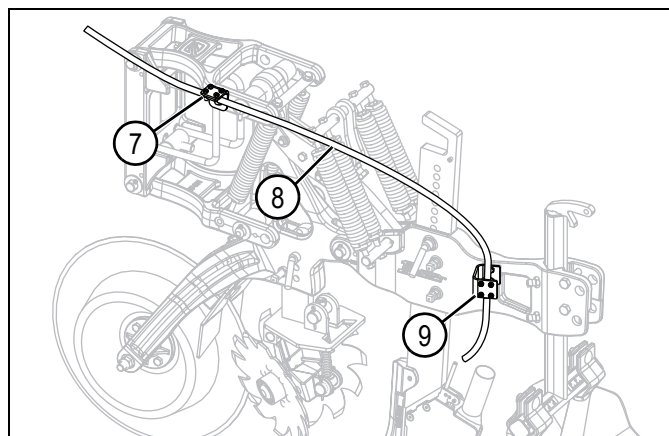

Figure 5-13

ORM000267

- | | |
|-----------------------------------|-------------------------|
| 7) Front routing bracket | 9) Back routing bracket |
| 8) Fertilizer tube (not included) | |

Adjustable Dry Fertilizer Boot on Dry Mole Shank

⚠ DANGER

Avoid direct exposure to anhydrous ammonia (NH₃) and liquid fertilizer. Failure to follow this information will result in death or serious injury.

If NH₃ or liquid fertilizer is used, it is advisable to consult documented information regarding safe handling and application of NH₃ or liquid fertilizer. Refer recognized sources. See “Anhydrous Ammonia (NH₃) and Liquid Fertilizer” on page 2-9.

The Orthman 1tRIPr® II Mole Shank Assembly can be used to place fertilizer at two different depths simultaneously, one of those options being dry fertilizer.

The adjustable dry fertilizer boot (8) can be used for applying dry fertilizer under the ground at various depths, and can also be used in conjunction with one liquid fertilizer tube. The adjustable dry fertilizer boot can be utilized in the lower settings on the shank side plate (5).

NOTE: *Running the adjustable dry fertilizer boot at a deeper setting may result in premature wear of the boot.*

The setting shown is approximately 5 in (12.7 cm) above the deepest part of the mole point. See Figure 5-14 on page 5-19. The holes in the side plate (5) are arranged vertically in 1 in (2.54 cm) increments. This will help calculate at what depth the user is applying fertilizer.

NOTE: *For example, if you have the shank set to till at a depth of 9 in (22.86 cm), the dry fertilizer boot would be applying the fertilizer at a depth of 4 in (10.16 cm).*

The top holes are used to retain the dry fertilizer boot adjustment (7). This holder may be used in the orientation shown for applying at deeper settings, and can be reversed to angle upwards for more clearance from the narrow, flat part of the boot when running at a more shallow setting.

NOTE: *The example shown is just one possible setting. The specific soil conditions, fertilizer placement points, and fertilizer amounts will vary due to each user's agronomic requirements.*

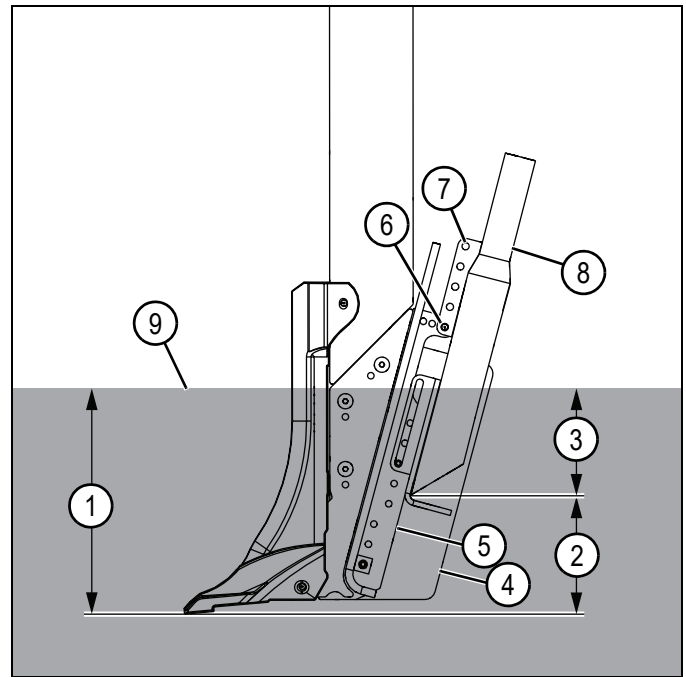

ORM000268

Figure 5-14: Adjustable Dry Fertilizer Boot on Mole Shank (wear plate removed for clarity)

- | | |
|--|-----------------------------------|
| 1) Shank till depth (9 in) | 6) Roll pin (3 used) |
| 2) Depth (5 in) | 7) Dry fertilizer boot adjustment |
| 3) Adjustable dry fertilizer boot depth (4 in) | 8) Adjustable dry fertilizer boot |
| 4) Replaceable side plate | 9) Ground surface |

The adjustable dry fertilizer boot is designed to work with a 1-1/4 in (3.18 cm) inside diameter hose. For more information, see “Dry Mole Shank Assembly Fertilizer Tube and Dry Boot Installation” on page 4-15.

NOTE: *If applying two different types of fertilizer, like NH₃ through one tube and liquid fertilizer through the other tube, it is the responsibility of the user to adequately insulate or add additional space between the tubes in order that the NH₃ does not freeze the liquid fertilizer tube.*

Shear Bolt Protected Tail

The 1tRIPr® II Row Unit has an optional shear bolt protected tail. The tail (2) is mounted to the main frame (4) with a shear bolt (1) and pivot pin (3).

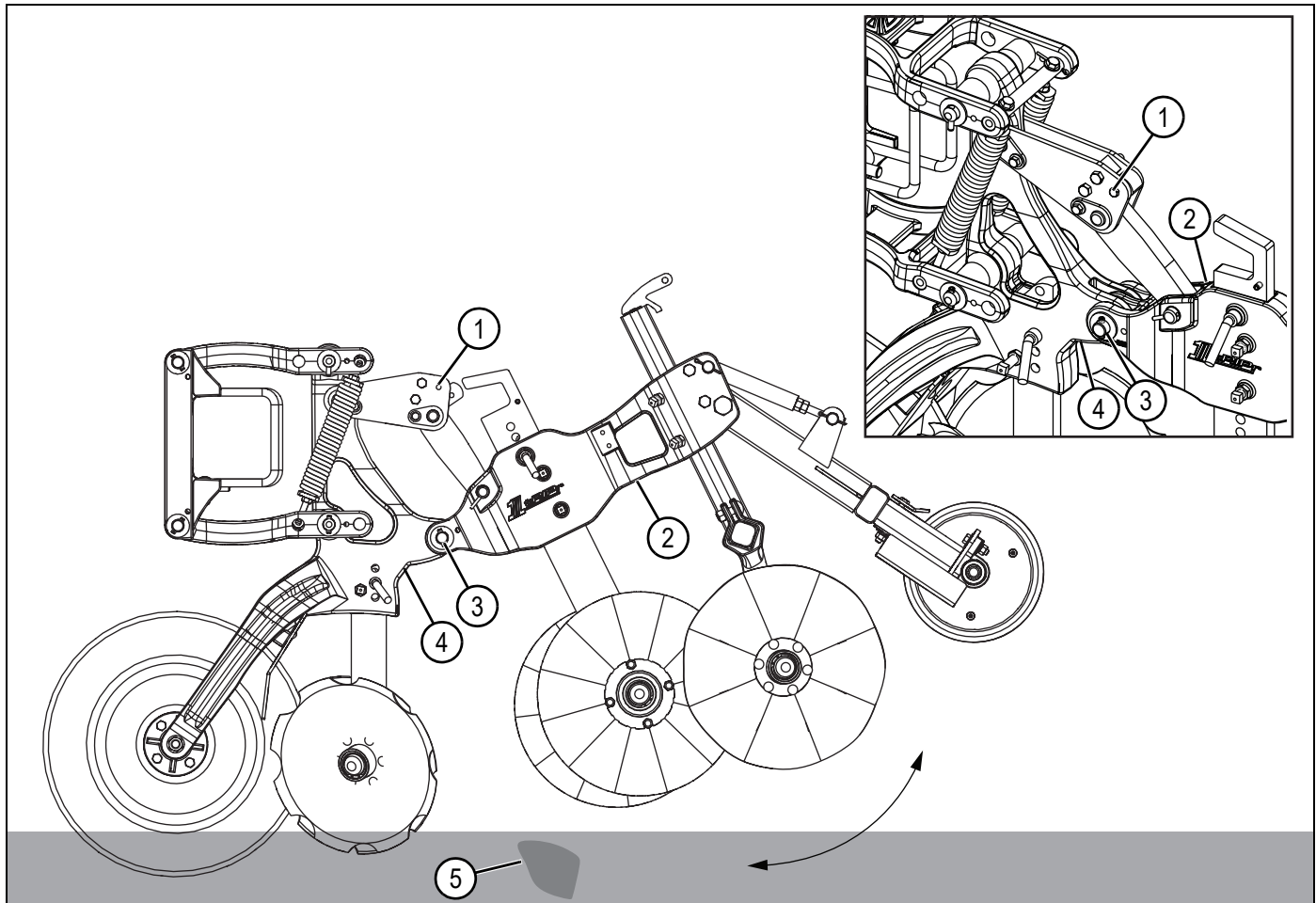

Figure 5-15

ORM000266

- 1) Shear bolt 2) Tail 3) Pivot pin 4) Main frame 5) Rock

The 1tRIPr® II Row Unit tail shear bolt is designed to protect the shank and other tail tooling from damage by shearing when a rock (5) or other obstacle is hit underground. This method is only meant for occasional tripping but is not effective in rocky conditions.

When the encounters an immovable object, the resulting force will shear the upper bolt, and the tail will rotate upward about the lower pivot pin to clear the obstacle.

NOTE: If the shear bolt is damaged, the operator should stop and replace the bolt. Orthman recommends using a grade 5 bolt for replacement. Higher or lower grade bolts may result in poor performance and cause damage to the implement.

CAUTION

Be careful to not over-tighten the shear bolt. This could exert a clamping load on the trip plate that will add resistance to the tail's ability to trip.

When installing the shear bolt, tighten it to the point where the nut will flatten a lock washer. If the bolt is tightened correctly, the tail should not be loose but will not have an excessive clamping load.

Automatic Reset (AR) Trip Linkage

The automatic reset (AR) trip linkage is engineered as a significant upgrade from a standard shear bolt for row unit and shank protection.

When a rock or other obstacle is hit underground, the row unit tail (1), which includes the shank (2), wavy coulters (3), and optional basket (4), can trip up and out of the ground.

When the obstacle is passed over, four powerful reset springs (5) will drive the 1tRIPr® II shank back into the ground. The AR trip linkage helps to protect valuable tooling from breaking and bending in rough and rocky soil conditions. The AR trip linkage may help, but will not prevent damage from occasional glancing blows.

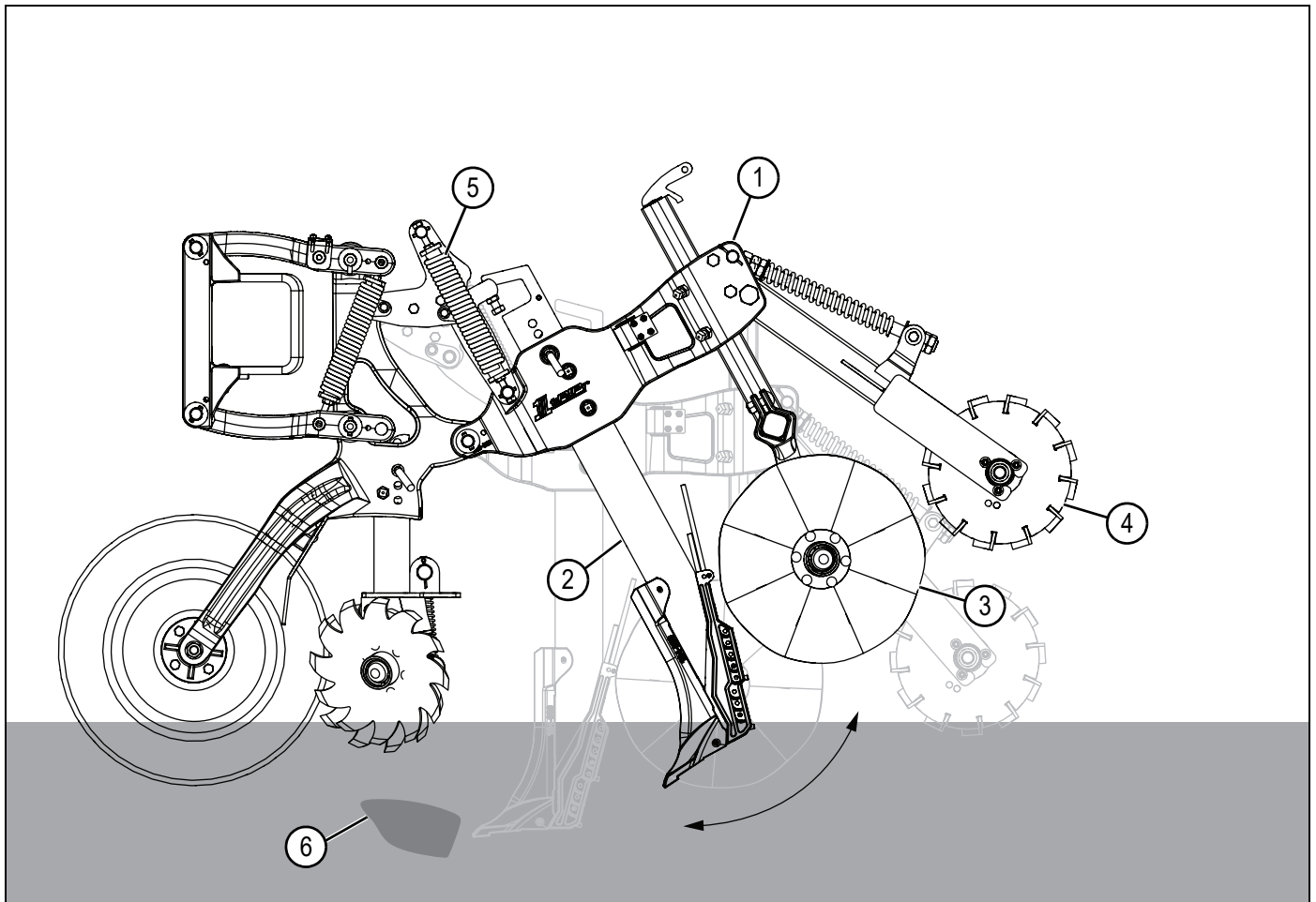

Figure 5-16

ORM000270

- | | | |
|------------------|--------------------------|--------------------------|
| 1) Row unit tail | 3) Wavy coulter (2 used) | 5) Reset spring (4 used) |
| 2) Shank | 4) Basket | 6) Rock |

OPERATION AND FIELD SETTINGS

The AR trip linkage comes set from the factory to trip easily, and will need to be adjusted to adapt to the specific operating conditions. It is important that the user understand how the AR trip linkage works and the results of the different adjustments.

Figure 5-17 identifies the important geometry points and adjustment locations. Without the AR trip linkage, the tail would be free to rotate about the pivot pin (7). The linkage installed keeps the tail from rotating about the pivot pin by creating a brace between point A and point B. That brace is made of two links (8) and ability to rotate in the middle at point C.

When the shank encounters an immovable object, the resulting force will rotate the linkage at point C, allowing the tail to rotate upward about the pivot pin until the obstacle is cleared. The upward rotation of the tail and the rotation of the linkage causes the four reset springs to stretch. The force stored in the stretched springs provides the power necessary to rotate the tail downward, which in turn drives the shank back into the ground and snaps the linkage back into place.

If you visualize a straight line between point A and point B, the distance that point C is away from that straight line directly affects how difficult it is to buckle the trip linkage.

NOTE: *The closer point C is to that line, the more difficult it is to trip. The further away point C is from that line, the easier it is to trip.*

CAUTION

Avoid injury. Springs are under tension. Adjust spring tension slowly. Failure to follow this information will result in serious injury.

The AR trip linkage comes set from the factory to trip easily. Operators can adjust this setting by loosening the jam nut (15) and adjusting the set bolt (16). One full turn of this set bolt represents about 1/8 in (0.32 cm). The set bolt setting (17) is measured from the stop block (13) to the rear trip link (14). See Figure 5-18 on page 5-23.

NOTE: *It may only be necessary to move the set bolt 1/8 in (0.32 cm) to 1/4 in (0.64 cm) to achieve the correct offset distance for the soil and desired tripping operation.*

The preset tension in the four reset springs will affect two things: the amount of force available to drive the shank back into the ground from the tripped position, and the amount of force required to trip the linkage. A higher spring tension will increase both of these.

The factory setting of the spring tension setting (9) is set to be 2 in (5.1 cm). This measurement may vary slightly due to differences in spring cut lengths and spring plug castings.

Spring tension adjustments can be made on either side of the four springs, with each spring adjusted equally. To adjust the spring tension, loosen the jam nuts (11) that are up tight against the spring plugs (10). While holding the spring from rotating, adjust the bolts (12) as desired. Tighten the jam nuts (11) to prevent the springs from coming loose.

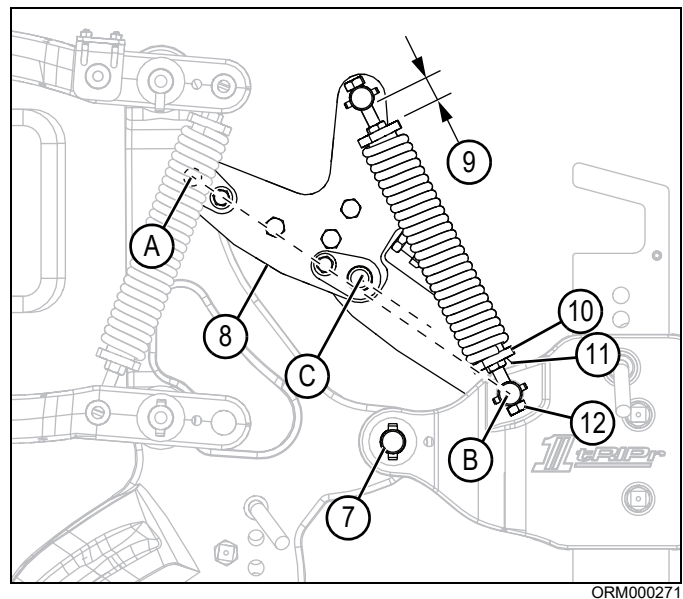

Figure 5-17: AR Trip Linkage

- | | |
|---------------------------|--------------------------|
| 7) Pivot pin | 10) Spring plug (8 used) |
| 8) Link (2 used) | 11) Jam nut (8 used) |
| 9) Spring tension setting | 12) Bolt (8 used) |

This table has been created to help understand the effects that the set bolt and spring tension setting have on the AR trip linkage's ability to trip. The numbers shown in the chart represent the estimated amount of force (lb/kg) that is required to trip the tail when the shank is at the deepest setting.

As the spring tension is increased (tightened up) and the set bolt setting is decreased (unscrewed), the force required to trip is increased.

		Distance	Spring Tension Setting		
			1-3/16 (3.02 cm)	1 in (2.54 cm)	7/8 in (2.22 cm)
Set Bolt Setting	4-1/2 full turns in	1/4 in (0.64 cm)	3352 lb (1520 kg)	6331 lb (2872 kg)	6703 lb (3040 kg)
	3-1/4 full turns in	3/16 in (0.48 cm)	4096 lb (1858 kg)	6889 lb (3125 kg)	7076 lb (3210 kg)
	2-1/4 full turns in	1/8 in (0.32 cm)	4841 lb (2196 kg)	7262 lb (3294 kg)	7262 lb (3294 kg)
	1 full turn in	1/16 in (0.16 cm)	5958 lb (2703 kg)	7448 lb (3378 kg)	*8193 lb (3716 kg)
	0 turns	0 in (0 cm)	*8565 lb (3885 kg)	*8938 lb (4054 kg)	*9682 lb (4392 kg)

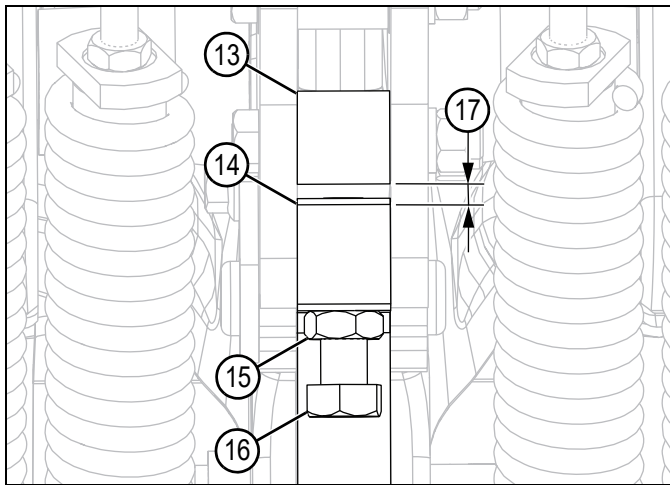

Figure 5-18: Set Bolt Setting

- 13) Stop block
- 14) Rear trip link
- 15) Jam nut
- 16) Set bolt
- 17) Set bolt setting

Orthman Manufacturing encourages the operator to start out at the factory setting, where the row unit tail will trip very easily. From that point adjust the set bolt and spring tension to attain the desired AR trip linkage setting.

The standard version of the 1tRIPr® II without the AR trip linkage is equipped with a shear bolt. See "Shear Bolt Protected Tail" on page 5-20. The amount of force it takes to shear this bolt is slightly over 8000 lb (3629 kg).

**Notice that the chart has values that exceeds 8000 lb (3629 kg). Orthman Manufacturing recommends using extreme caution when adjusting the AR trip linkage to a setting above 8000 lb (3629 kg). Using a setting that exceeds the 8000 lb (3629 kg) mark is likely to increase the chances of damaging the shank in the event an obstacle is encountered.*

Page Intentionally Blank

Chapter 6

Troubleshooting

Row Unit Tooling Does Not Penetrate Soil. Wing Row Units Float Upward.	6-2
Row Unit Plugs With Field Residue Between the Depth Band Coulter Assembly and Row Cleaner Assembly	6-2
Row Unit Plugs With Field Residue Between the Row Cleaner Assembly and Tillage Shank.	6-2
Row Unit Plugs With Field Residue Between the Tillage Shank and Wavy Coulters.	6-2
Field Residue Plugs Between Row Units.	6-3
Row Unit Does Not Trip or Trips Too Easily.	6-3
Shear Bolt Will Not Shear or Shears Too Easily.	6-3

Row Unit Tooling Does Not Penetrate Soil. Wing Row Units Float Upward.

Field height conditions can vary causing the 1tRIPr II® Row Unit not to penetrate the soil.

- Adjust toolbar height and orientation. See “Toolbar Height and Orientation” on page 5-2.
- Adjust row unit down pressure. See “Row Unit Down Pressure” on page 5-4.
- Raise wavy coulter assembly. Wavy coulters can act as a footprint and prevent soil penetration. See “Wavy Coulter Assembly Depth and Width” on page 5-14.
- Lower tillage shank. See “Tillage Shank Assembly Depth” on page 5-12.

Row Unit Plugs With Field Residue Between the Depth Band Coulter Assembly and Row Cleaner Assembly.

Wet or damp field conditions can adversely affect the performance of the 1tRIPr II® Row Unit. Typically, wet or damp field conditions do not allow residue to pass through the row unit as effectively as drier conditions.

- Adjust toolbar height and orientation. See “Toolbar Height and Orientation” on page 5-2.
- Alter ground speed to change rate at which field residue passes through row unit tooling. Slower ground speeds generally reduce plugging by allowing residue to pass smoothly through row unit tooling.
- Raise row cleaner assembly. See “Row Cleaner Assembly Depth” on page 5-6.
- Adjust row cleaner width. See “Row Cleaner Assembly Width” on page 5-8.
- Remove row cleaner assembly. See “Row Cleaner Assembly Depth” on page 5-6.

Row Unit Plugs With Field Residue Between the Row Cleaner Assembly and Tillage Shank.

Wet or damp field conditions can adversely effect the performance of the 1tRIPr II® Row Unit. Typically, wet or damp field conditions do not allow residue to pass through the row unit as effectively as drier conditions.

- Lower row cleaner assembly to reduce the amount of field residue in front of the tillage shank. See “Row Cleaner Assembly Depth” on page 5-6.
- Adjust toolbar height and orientation. See “Toolbar Height and Orientation” on page 5-2.
- Alter ground speed to change rate at which field residue passes through row unit tooling. Slower ground speeds generally reduce plugging by allowing residue to pass smoothly through row unit tooling.
- Adjust row cleaner width. See “Row Cleaner Assembly Width” on page 5-8.

Row Unit Plugs With Field Residue Between the Tillage Shank and Wavy Coulters.

Wet or damp field conditions can adversely effect the performance of the 1tRIPr II® Row Unit. Typically, wet or damp field conditions do not allow residue to pass through the row unit as effectively as drier conditions.

- Adjust wavy coulter tillage width. Increasing tillage width should allow residue to pass between the wavy coulters. See “Wavy Coulter Assembly Depth and Width” on page 5-14.

NOTE: *It is not recommended for the wavy coulter tillage width to exceed the width at which row cleaners remove residue. If wavy coulter tillage zone exceeds the residue free strip, the wavy coulters are more likely to plug and not penetrate the soil.*

- Adjust wavy coulter assembly to increase distance between tillage shank assembly and wavy coulter assembly. See “Wavy Coulter Assembly Fore and Aft” on page 5-16.

NOTE: *Increasing the distance relationship between row unit tooling usually increases the ability of field residue to pass through the row unit without plugging.*

- Alter ground speed to change rate at which field residue passes through row unit tooling. Slower ground speeds generally reduce plugging by allowing residue to pass smoothly through row unit tooling.

Field Residue Plugs Between Row Units.

Wet or damp field conditions can adversely effect the performance of the 1tRIPr II® Row Unit. Typically, wet or damp field conditions do not allow residue to pass through the row unit as effectively as drier conditions.

- Raise row cleaner assembly to reduce the amount of field residue passing between row units. See “Row Cleaner Assembly Depth” on page 5-6.
- Alter ground speed to change rate at which field residue passes through row unit tooling. Slower ground speeds generally reduce plugging by allowing residue to pass smoothly through row unit tooling.
- Decrease wavy coulter tillage width. See “Wavy Coulter Assembly Depth and Width” on page 5-14.
- Increase distance between tillage shank assembly and wavy coulter assembly. See “Wavy Coulter Assembly Fore and Aft” on page 5-16.
- Adjust row cleaner width. See “Row Cleaner Assembly Width” on page 5-8.

Row Unit Does Not Trip or Trips Too Easily.

Check to see if the automatic reset (AR) trip linkage is installed correctly. See “Automatic Reset (AR) Trip Linkage Installation” on page 4-17.

See “Automatic Reset (AR) Trip Linkage” on page 5-21.

Shear Bolt Will Not Shear or Shears Too Easily.

See “Shear Bolt Protected Tail” on page 5-20.

Page Intentionally Blank

Chapter 7

Maintenance and Specifications

Practice Safe Maintenance	7-2
Torque Specifications	7-2
Standard Fasteners	7-2
Metric Fasteners	7-3
Lubrication	7-4
Implement Inspection	7-4
Implement Storage	7-4
Specifications	7-5
Notes	7-8

Practice Safe Maintenance

Proper maintenance is your responsibility. Maintenance neglect and/or poor maintenance practices can result in injury or death. Always use the proper tools to maintain the implement. For more information on practicing safe maintenance, see “Practice Safe Maintenance” on page 2-8.

Torque Specifications

Standard Fasteners

Unified bolt and screw torque values:

Bolt or Screw Size (inches)	SAE Grade 1				SAE Grade 2				SAE Grade 5, 5.1, or 5.2				SAE Grade 8 or 8.2			
	Lubricated		Dry		Lubricated		Dry		Lubricated		Dry		Lubricated		Dry	
	N•m	lb-in	N•m	lb-in	N•m	lb-in	N•m	lb-in	N•m	lb-in	N•m	lb-in	N•m	lb-in	N•m	lb-in
1/4	3.7	33	4.7	42	6	53	7.5	66	9.5	84	12	106	13.5	120	17	150
													N•m	lb-ft	N•m	lb-ft
5/16	7.7	68	9.8	86	12	106	15.5	137	19.5	172	25	221	28	20.5	35	26
									N•m	lb-ft	N•m	lb-ft				
3/8	13.5	120	17.5	155	22	194	27	240	35	26	44	32.5	49	36	63	46
			N•m	lb-ft	N•m	lb-ft	N•m	lb-ft								
7/16	22	194	28	20.5	35	26	44	32.5	56	41	70	52	80	59	100	74
	N•m	lb-ft														
1/2	34	25	42	31	53	39	67	49	85	63	110	80	120	88	155	115
9/16	48	35.5	60	45	76	56	95	70	125	92	155	115	175	130	220	165
5/8	67	49	85	63	105	77	135	100	170	125	215	160	240	175	308	225
3/4	120	88	150	110	190	140	240	175	300	220	380	280	425	315	540	400
7/8	190	140	240	175	190	140	240	175	490	360	615	455	690	510	870	640
1	285	210	360	265	285	210	360	265	730	540	920	680	1030	760	1300	960
1-1/8	400	300	510	375	400	300	510	375	910	670	1150	850	1450	1075	1850	1350
1-1/4	570	420	725	535	570	420	725	535	1280	945	1630	1200	2050	1500	2600	1920
1-3/8	750	550	950	700	750	550	950	700	1700	1250	2140	1580	2700	2000	3400	2500
1-1/2	990	730	1250	930	990	730	1250	930	2250	1650	2850	2100	3600	2650	4550	3350

Torque values listed are for general use only, based on the strength of the bolt or screw. DO NOT use these values if a different torque value or tightening procedure is given for a specific application. For plastic insert or crimped steel type lock nuts, for stainless steel fasteners, or for nuts on U-bolts, see the tightening instructions for the specific application. Shear bolts are designed to fail under predetermined loads. Always replace shear bolts with identical grade. Replace fasteners with the same or higher grade. If higher grade fasteners are used, tighten these to the strength of the original. Make sure fastener threads are clean and that you properly start thread engagement. When possible, lubricate plain or zinc plated fasteners other than lock nuts, wheel

bolts, or wheel nuts, unless different instructions are given for the specific application.

Grade 2 applies to hex cap screws (not hex bolts) up to 6 in (152 mm) long. Grade 1 applies to hex cap screws over 6 in (152 mm) long, and for all other types of bolts and screws of any length.

“Lubricated” means coated with a lubricant such as engine oil, fasteners with phosphate and oil coatings, or 7/8 in. and larger fasteners with JDM F13C zinc flake coating.

“Dry” means plain or zinc plated without any lubrication, or 1/4 to 3/4 in. fasteners with JDM F13B zinc flake coating.

Metric Fasteners

Metric bolt and screw torque value:

Bolt or Screw Size (mm)	Class 4.8				Class 8.8 or 9.8				Class 10.9				Class 12.9			
	Lubricated		Dry		Lubricated		Dry		Lubricated		Dry		Lubricated		Dry	
	N•m	lb-in	N•m	lb-in	N•m	lb-in	N•m	lb-in	N•m	lb-in	N•m	lb-in	N•m	lb-in	N•m	lb-in
M6	4.7	42	6	53	8.9	79	11.3	100	13	115	16.5	146	15.5	137	195	172
									N•m	lb-ft	N•m	lb-ft	N•m	lb-ft	N•m	lb-ft
M8	11.5	102	14.5	128	22	194	27.5	243	32	23.5	40	29.5	37	27.5	47	35
			N•m	lb-ft	N•m	lb-ft	N•m	lb-ft								
M10	23	204	29	21	43	32	55	40	63	46	80	59	75	55	95	70
	N•m	lb-ft														
M12	40	29.5	50	37	75	55	95	70	110	80	140	105	130	95	165	120
M14	63	46	80	59	120	88	150	110	175	130	220	165	205	150	260	190
M16	100	74	125	92	190	140	240	175	275	200	350	255	320	235	400	300
M18	135	100	170	125	265	195	330	245	375	275	475	350	440	325	560	410
M20	190	140	245	180	375	275	475	350	530	390	675	500	625	460	790	580
M22	265	195	330	245	510	375	650	480	725	535	920	680	580	625	1080	800
M24	330	245	425	315	650	480	820	600	920	680	1150	850	1080	800	1350	1000
M27	490	360	625	460	950	700	1200	885	1350	1000	1700	1250	1580	1160	2000	1475
M30	660	490	850	625	1290	950	1630	1200	1850	1350	2300	1700	2140	1580	2700	2000
M33	900	665	1150	850	1750	1300	2200	1625	2500	1850	3150	2325	2900	2150	3700	2730
M36	1150	850	1450	1075	2250	1650	2850	2100	3200	2350	4050	3000	3750	2770	4750	3500

Torque values listed are for general use only, based on the strength of the bolt or screw. DO NOT use these values if a different torque value or tightening procedure is given for a specific application. For plastic insert or crimped steel type lock nuts, for stainless steel fasteners, or for nuts on U-bolts, see the tightening instructions for the specific application.

Shear bolts are designed to fail under predetermined loads. Always replace shear bolts with identical grade.

Replace fasteners with the same or higher grade. If higher grade fasteners are used, tighten these to the strength of the original. Make sure fastener threads are clean and that you properly start thread engagement. When possible, lubricate plain or zinc plated fasteners other than lock nuts, wheel bolts, or wheel nuts, unless different instructions are given for the specific application.

"Lubricated" means coated with a lubricant such as engine oil, fasteners with phosphate and oil coatings, or M20 and larger fasteners with JDM F13C zinc flake coating.

"Dry" means plain or zinc plated without any lubrication, or M6 to M18 fasteners with JDM F13B zinc flake coating.

Lubrication

To reduce maintenance, the 1tRIPr® II Row Units are completely greaseless. However, lubrication is an important part to prolonging the life of implement components. See the Orthman toolbar operator manual for lubrication service intervals and zerk locations.

The purpose of lubrication on machines with moving parts is to prevent metal-on-metal contact.

Metal-on-metal contact creates premature wearing of the connective components. Premature wearing of connective components can lead to non-warrantable, catastrophic failure of a machine.

During the off-season, moisture and dust can contaminate grease in moving points of a machine that are not sealed, such as pins. This can lead to seized pins. For this reason, machine lubrication points should always be lubricated with grease before first time use.

Always use clean, high-quality grease for lubricating machine. The grease should be selected on the basis of the environment the machine will operate in, such as temperature, humidity, etc.

Chains also need adequate lubrication. Lubrication allows a chain to move smoothly with reduced friction and prevents premature stretching of the chain.

Implement Inspection

Before each use, inspect implement for damaged or broken parts. Replace broken or worn parts immediately. When replacement parts are necessary for periodic maintenance and servicing, genuine factory replacement parts must be used in order to restore the implement to original specifications. Contact your Orthman dealer for replacement parts.

During break-in (40 hours), check hardware for proper torque every 10 to 20 hours. See “Torque Specifications” on page 7-2. Before each use, check hardware for wear and proper torque. Replace damaged or missing hardware with hardware of an identical grade to restore the implement to original specifications.

Remove any buildup of grease, oil, and debris.

Replace all shields and guards. Be sure all tools, parts, and service equipment are removed before you operate the implement.

Implement Storage

Prior to storing the implement for a long period of time, perform the following:

- Restore the 1tRIPr® II Row Units to shipping configuration. For more information, see “Shipping Configuration” on page 4-2.
- Clean and touch up paint seasonally to avoid corrosion and rust. Contact your Orthman dealer for touch up paint.
- Inspect all safety decals and replace if missing or damaged. Contact your Orthman dealer for replacement decals. See “” on page 2-9.
- Grease all zerks regardless of hourly interval. See “Lubrication” on page 7-4.
- Check all hardware according to torque specifications. See “Torque Specifications” on page 7-2.
- Inspect implement for damaged or broken parts. Replace parts as necessary.
- Remove any buildup of grease, oil, and debris.

Store inside if possible. Storing the implement inside will prolong the life of the components.

DANGER

Avoid crushing. Failure to follow this information will result in death or serious injury. Use bar stands and cylinder stops to support the implement.

Store the implement on a clean, dry, level surface. An uneven surface could cause the implement to shift or fall, resulting in injury or death as well as implement damage. Securely support all implement components that must be raised. Store the implement away from human activity.

DANGER

Avoid crushing. Failure to follow this information will result in death or serious injury. Make sure all personnel are clear of the implement before lowering.

Lower the implement to the ground, place the tractor in park, turn off the engine, and remove the key.

Specifications

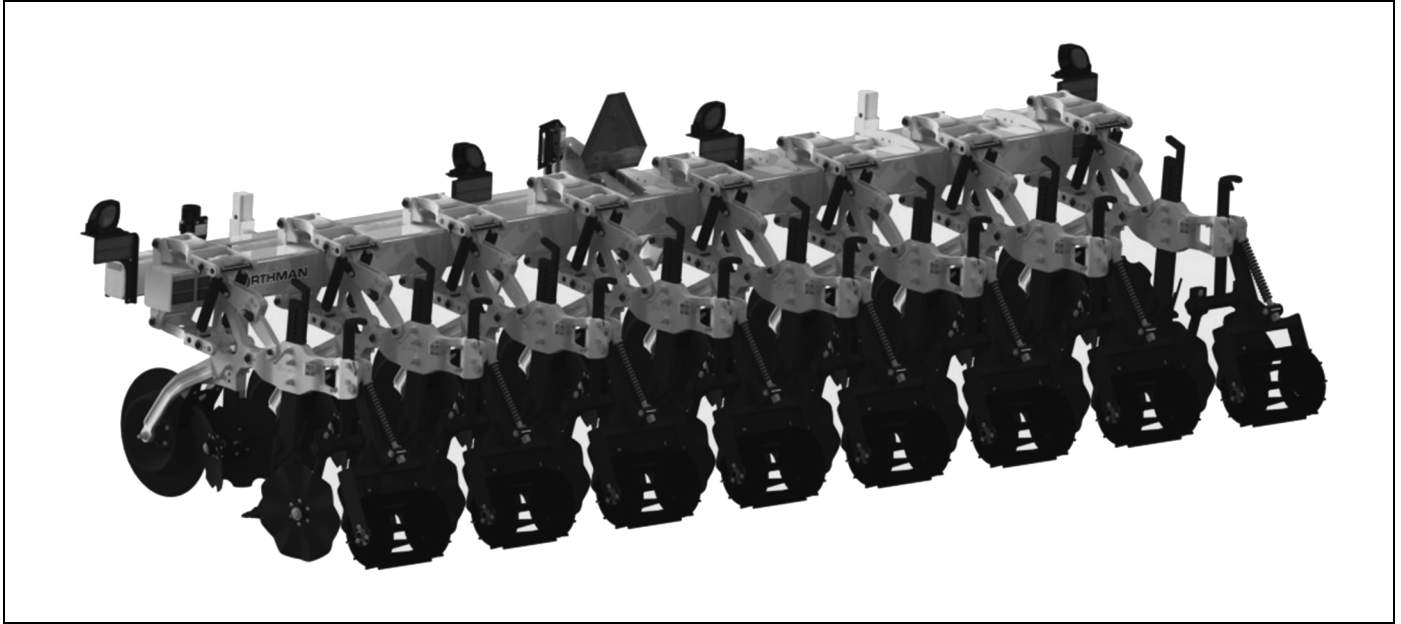

Figure 7-1: Rigid Machine (8 rows)

ORM000262

	Number of Rows	Row Spacing	Weight	Transport Width
Mounted Rigid Machines	4	22–30 in (50.8–76.2 cm)	3350 lb (1520 kg)	10 ft (3.3 m)
	4	36–40 in (91.4–101.6 cm)	3550 lb (1610 kg)	12 ft (3.7 m)
	6	22–30 in (50.8–76.2 cm)	4707 lb (2135 kg)	15 ft (4.6 m)
	6	36–40 in (91.4–101.6 cm)	4940 lb (2241 kg)	19 ft (5.8 m)
	8	22 in (50.8 cm)	5864 lb (2660 kg)	15 ft (4.6 m)
	8	30 in (76.2 cm)	6075 lb (2756 kg)	20 ft (6.1 m)
	8	36–38 in (91.4–96.5 cm)	6205 lb (2815 kg)	24 ft (7.3 m)
	8	38–40 in (96.5–101.6 cm)	6250 lb (2835 kg)	25 ft (7.6 m)
	10	30 in (76.2 cm)	7591 lb (3443 kg)	20.1 ft (6.1 m)
	12	22 in (50.8 cm)	8650 lb (3924 kg)	22.8 ft (6.9 m)
	12	30 in (76.2 cm)	9200 lb (4173 kg)	30.1 ft (9.2 m)

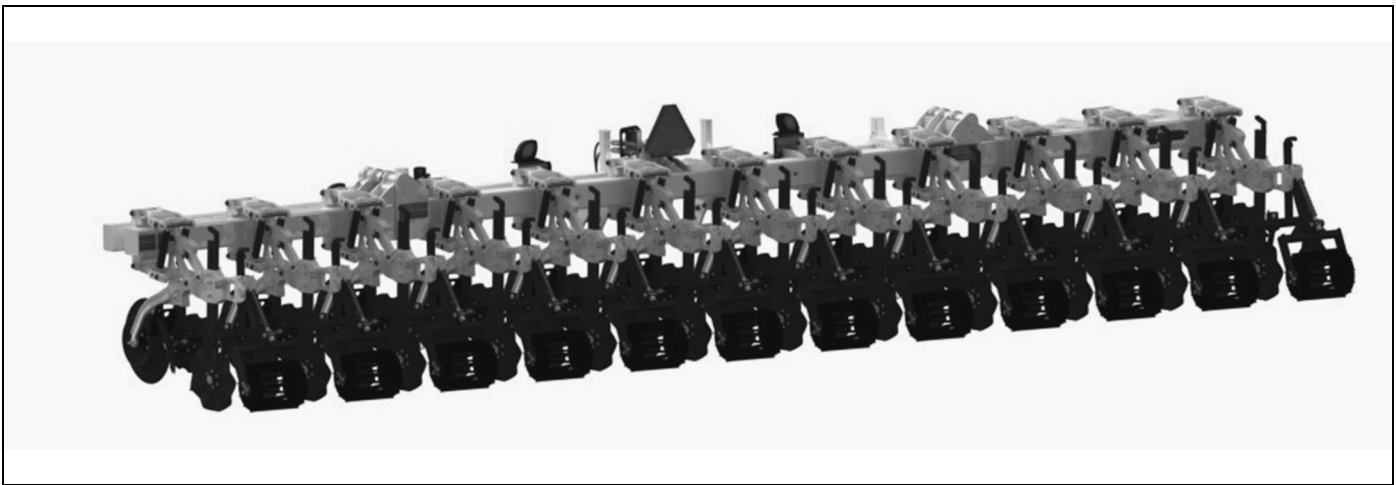

Figure 7-2: Folding Machine (12 rows)

ORM000263

	Number of Rows	Row Spacing	Weight	Transport Width
Mounted Folding Machines	8	30 in (76.2 cm)	6790 lb (3080 kg)	11.7 ft (3.9 m)
	8	36 in (91.4 cm)	7072 lb (3208 kg)	13.8 ft (4.6 m)
	8	38–40 in (96.5–101.6 cm)	7164 lb (3250 kg)	14.7 ft (4.9 m)
	12	30 in (76.2 cm)	9660 lb (4382 kg)	16.7 ft (5.6 m)
	12	36 in (91.4 cm)	9883 lb (4483 kg)	19.3 ft (6.4 m)
	12	38–40 in (96.5–101.6 cm)	10155 lb (4606 kg)	21.3 ft (7.1 m)
	16	30 in (76.2 cm)	12368 lb (5610 kg)	21.7 ft (7.2 m)
	16	38–40 in (96.5–101.6 cm)	15764 lb (7150 kg)	28.1 ft (9.4 m)

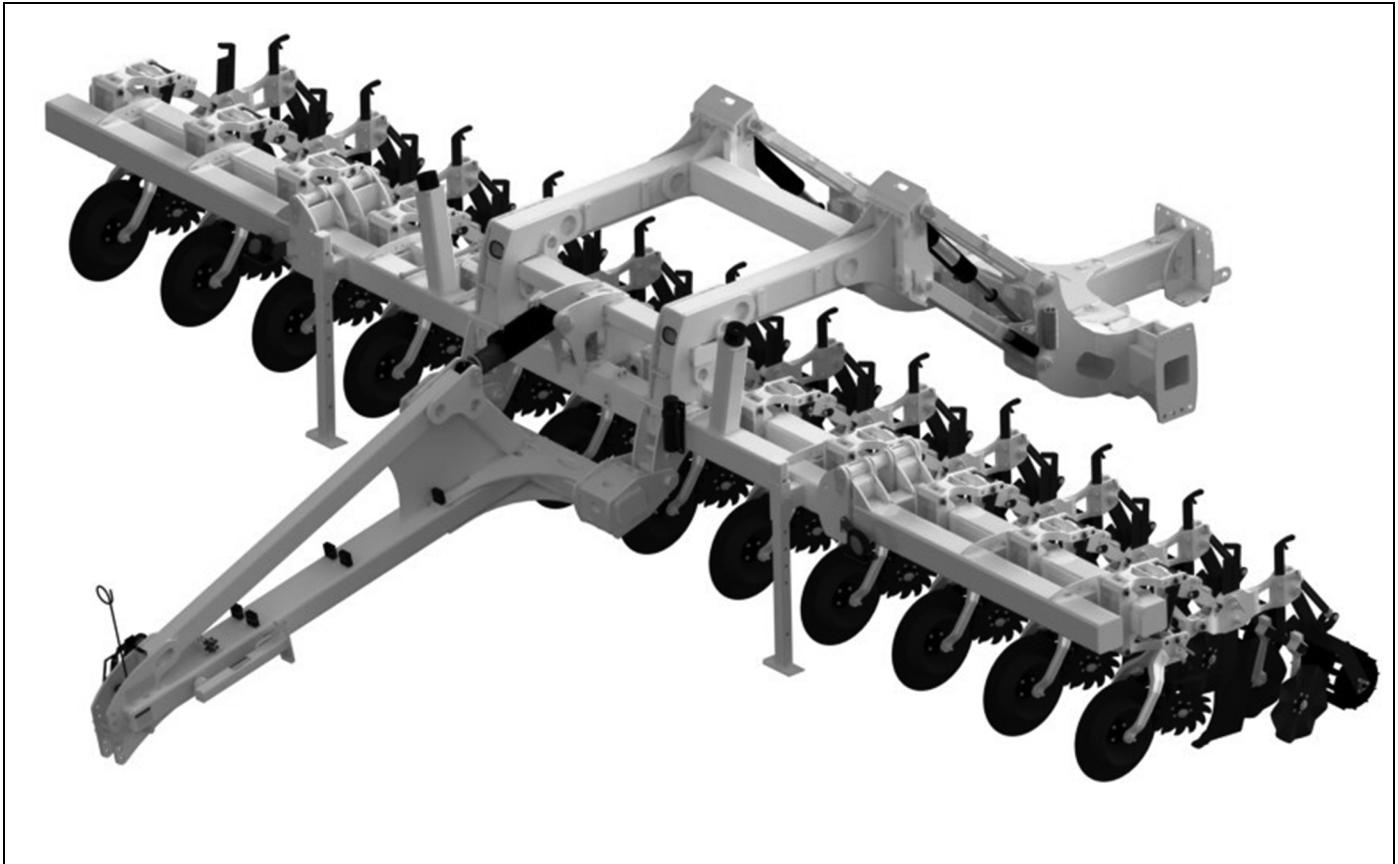

Figure 7-3: XD Machine (12 rows)

ORM000264

	Number of Rows	Row Spacing	Weight	Transport Width
XD Machines	8	30 in (76.2 cm)	14877 lb (6748 kg)	11.2 ft (3.4 m)
	12	30 in (76.2 cm)	17774 lb (8062 kg)	16.2 ft (4.9 m)
	12*	30 in (76.2 cm)	19255 lb (8734 kg)	11.3 ft (3.4 m)
	12	36 in (91.4 cm)	19067 lb (8649 kg)	18.9 ft (5.8 m)
	16	30 in (76.2 cm)	21845 lb (9909 kg)	21.3 ft (6.5 m)
	16*	30 in (76.2 cm)	22403 lb (10162 kg)	16.3 ft (5.0 m)
	16	36 in (91.4 cm)	22454 lb (10185 kg)	25 ft (7.2 m)
	18	30 in (76.2 cm)	23464 lb (10643 kg)	26.5 ft (7.6 m)
	18*	30 in (76.2 cm)	23749 lb (10772 kg)	16.3 ft (5.0 m)

*Indicated narrow transport option.

	Number of Rows	Row Spacing	Weight	Transport Width
XD Combo Machines	8	30 in (76.2 cm)	16210 lb (7353 kg)	11.2 ft (3.4 m)
	12	30 in (76.2 cm)	18783 lb (8520 kg)	16.2 ft (4.9 m)
	16	30 in (76.2 cm)	24638 lb (11176 kg)	21.3 ft (6.5 m)

Index

A

AA knife	
Overview	4-10
Adjustments	
AR trip linkage	5-21
Dry boot	5-19
Fertilizer tubes	5-18
Rolling basket down pressure	5-11
Row cleaner depth	5-6
Row cleaner width	5-8
Row unit	5-4
Row unit down pressure	5-5
Tillage shank depth	5-12
Wavy coulter depth	5-14
Wavy coulter fore and aft	5-16
Wavy coulter width	5-15
Air diffuser	
Installation	4-11
Anhydrous ammonia. See Liquid fertilizer	
AR trip linkage. See Automatic reset (AR) trip linkage	
Automatic reset (AR) trip linkage	
Adjustment	5-21
Installation	4-17
Overview	5-21
Troubleshooting	6-3

C

Component identification	
Depth band coulter	3-2
Main frame	3-2
Roller	3-5
Rolling basket	3-4
Row cleaner	3-2
Tail section	3-3
Tillage shank	3-3
Wavy coulter	3-3

D

Delivery	
Checklist	1-2
Pre-delivery checklist	1-2
Shipping configuration	4-2

Depth band coulter	
Component identification	3-2
Dry boot	
Adjustments	5-19
Installation on dry mole shank	4-15
Dry mole shank	
Boot and tube installation	4-15
Depth adjustment	5-12
Dry boot adjustments	5-19
Installation	4-12
Overview	4-11
Shin cap installation	4-16

F

Fertilizer tube	
Adjustments	5-18
Installation on dry mole shank	4-15
Installation on mole knife	4-14
Installation on mole shank	4-13

I

Implement	
Connecting to tractor	4-3
Inspection	7-4
Orientation	5-2
Storage	7-4
Installation	
Air diffuser	4-11
AR trip linkage	4-17
Dry mole shank boot	4-15
Fertilizer tube on mole knife	4-14
Fertilizer tube on mole shank	4-13
Rolling basket	4-8
Shin cap	4-16
Tillage shank	4-12

K

Knife	
AA knife	4-10
Mole knife	4-10

L

Liquid fertilizer	
Safety	2-9
Liquid fertilizer mole shank	
Depth adjustment	5-12
Fertilizer tube installation	4-13
Installation	4-12
Overview	4-9
Lubrication	
Specifications	7-4

M

Main frame	
Component identification	3-2
Maintenance	
Implement inspection	7-4
Implement storage	7-4
Lubrication	7-4
Notes	7-8
Safety	7-2
Torque specifications	7-2
Mole knife	
Fertilizer tube installation	4-14
Overview	4-10
Mole shank	
Installation	4-12
Shin cap installation	4-16
Mounting	
Row unit	4-4
Set-back clamp	4-6

P

Preparation	
Row unit	4-2

R

Roller	
Component identification	3-5
Installation	4-8
Rolling basket	
Component identification	3-4
Down pressure adjustment	5-11
Installation	4-8

Row cleaner	
Component identification	3-2
Depth adjustment	5-6
Troubleshooting	6-2
Width adjustment	5-8

Row unit	
Adjustments	5-4
Air diffuser	4-11
AR trip linkage	4-17
Down pressure	5-4
Down pressure adjustment	5-5
Mounting	4-4
Orientation	5-2
Preparation	4-2
Rolling basket	4-8
Set-back clamp	4-6
Shipping configuration	4-2
Tillage shank	4-9
Troubleshooting	6-2, 6-3

S

Safety	
Decals	2-9
Farm	2-2
Farm hazards	2-3
Liquid fertilizer	2-9
Maintenance	2-8, 7-2
Operation	2-5
Shutdown and storage	2-4
Slow moving vehicle	2-7
Symbols	2-4
Transport	2-5, 2-7
Warning lights	2-6

Serial number plate	
Description	2-9

Set-back clamp	
Mounting	4-6

Shallow tillage assembly	
Depth Adjustment	5-12
Installation	4-12
Overview	4-9

Shear bolt	
Overview	5-20
Troubleshooting	6-3

Shin cap	
Installation	4-16

Slow moving vehicle (SMV)	
Safety	2-7

SMV. See Slow moving vehicle (SMV)

Specification	
General	7-5
Lubrication	7-4
Torque	7-2
Storage	
Maintenance	7-4

T

Tail section	
Component identification	3-3
Tillage shank	
AA knife	4-10
Component identification	3-3
Depth adjustment	5-12
Dry mole shank	4-11
Installation	4-12
Liquid fertilizer mole shank	4-9
Mole knife	4-10
Overview	4-9
Shallow tillage assembly	4-9
Troubleshooting	6-2
Toolbar. See Implement	
Tooling	
Air diffuser	4-11
AR trip linkage	4-17
Rolling basket	4-8
Row unit	4-4
Set-back clamp	4-6
Tillage shank	4-9
Torque	
Metric fasteners	7-2
Standard fasteners	7-2
Troubleshooting	
AR trip linkage	6-3
Row cleaner	6-2
Row unit	6-2, 6-3
Shear bolt	6-3
Tillage shank	6-2
Wavy coulters	6-2

W

Warranty	1-4
Wavy coulter	
Component identification	3-3
Depth adjustment	5-14
Fore and aft adjustment	5-16
Troubleshooting	6-2
Width adjustment	5-15

ORTHMAN MFG

75765 Road 435

Lexington, NE 68850

USA Ag Products: 308-324-4654

USA Repair Parts: 866-324-7519

South Africa Ag Products: (+27) 12-940-2155

For repair parts or service contact your certified Orthman dealer.

Orthman.com

